

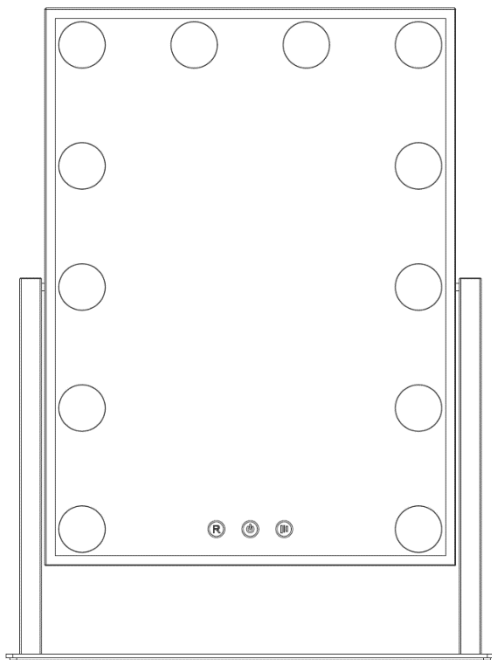

# MEIKKIPEILI

KÄYTTÖOHJE

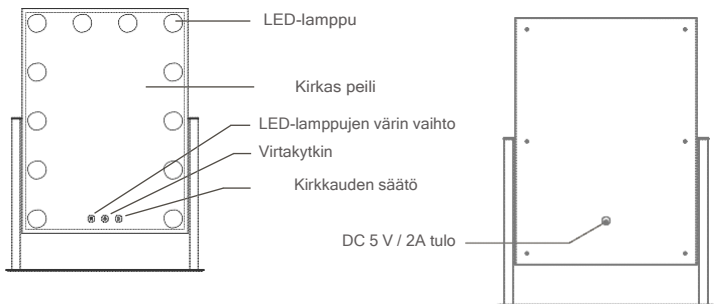



## TEKNISET TIEDOT

[Tuotteen nimi] Lumio Lights Hollywood Meikkipeili

[Tuotenumero] 102820762 & 102820764

[Materiaali] Metallia ja lasia

[LED-väriämpötila] 6 500 / 3 500 K  $\pm$  500 K

[LED kirkkaus] 60–80 lm

[Virtalähde] USB 5 V / 1 A

[Nettopaino] 2 680  $\pm$  20 g

[Tuotteen koko] 36 x 47,5 x 7,5 cm

[Pakkauksen koko] 52 x 13,5 x 40 cm

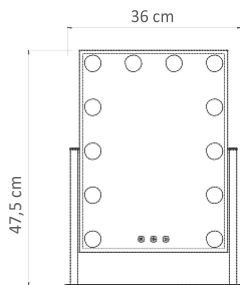

## OMINAISUUDET



3 mm:n paksuinen kirkas ja ympäristöystävällinen lasipeili



Valaistussa meikkipeilissä on energiatehokkaat LED-valot



Voit valita lämpimän, luonnollisen ja kylmän valon väliillä



Sisäänrakennettu kosketusanturi-kytkin



Voidaan kääntää 360 astetta



Virta syötetään verkkolaitteella, mukana USB

# PAKKAUSLUETTELO



Meikkipeili





USB - kaapeli



Käyttöopas

## KÄYTTÖ

- (1) Käytä alkuperäistä USB 5 V / 1 A kaapelia. Liitä johto takana olevaan porttiin.
- (2) Paina  kytkeäksesi valot päälle/pois.  
Kirkkaus on aluksi 100 %.
- (3) Paina  valitaksesi lämpimän, luonnollisen ja kylmän valon välillä.
- (4) Paina  pitkään kirkkauden säätämiseksi.
- (5) Irrota verkkolaite, kun tuotetta ei käytetä.

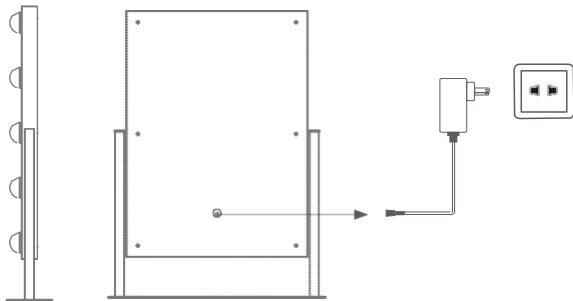
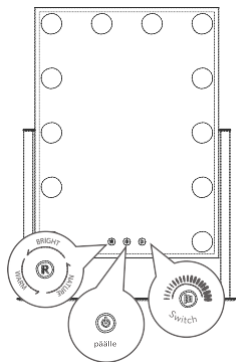



Made in China

## TURVALLISUUS

---

- ⚠ Lue nämä turvaohjeet huolellisesti ennen tuotteen käyttöä.
  - ⚠ Älä pura tai muuta peilin osia.
  - ⚠ Paina kosketusanturia kevyesti.
  - ⚠ Pidä peili kuivana. Kosteus vähentää laitteen herkkyyttä.
  - ⚠ Sammuta valot ja irrota verkkolaite ennen puhdistamista. Käytä lasinpuhdistusainetta. Varmista, että peili on täysin kuiva ennen kuin käytät sitä.
  - ⚠ Katkaise virta ja suojaa suoralta auringonvalolta, kun peili laitetaan säilöön pitkäksi aikaa, ja pidä se poissa lasten ulottuvilta.
  - ⚠ Ennen kuin käytät peiliä, varmista, että verkkolaitteen jännite on riittävä.
  - ⚠ Tulipalon tai räjähdyksen sattuessa älä koske peiliin tai heitä sitä tuleen.
  - ⚠ Lopeta peilin käyttö, jos jotain epätavallista ilmenee.
- \* Pidätämme oikeiden tuotteen suunnitteluun ja eritelmiin liittyviin muutoksiin. Kaikki luetellut materiaalit ovat vain viitteellisiä. Teknisten tietojen muutoksista ei ilmoiteta erikseen.

**SUOMITRADING**

Suomi Trading Oy  
Realparkinkatu 12, 37570 Lempäälä  
[asiakaspalvelu@suomitrading.fi](mailto:asiakaspalvelu@suomitrading.fi)



# SMINKSPEGEL

---

## BRUKSANVISNING

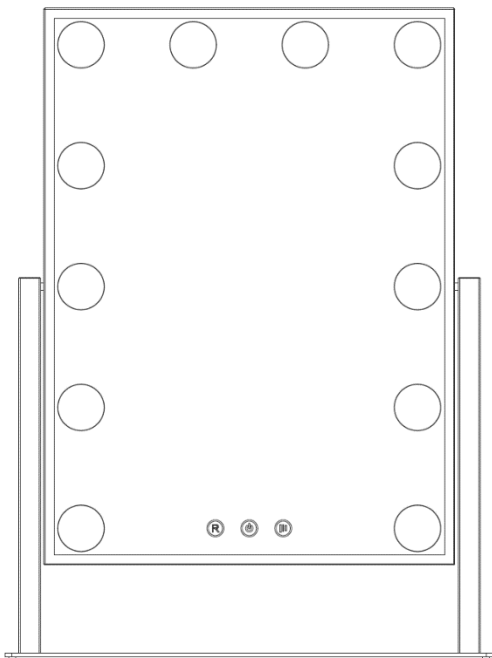

## BESKRIVNING

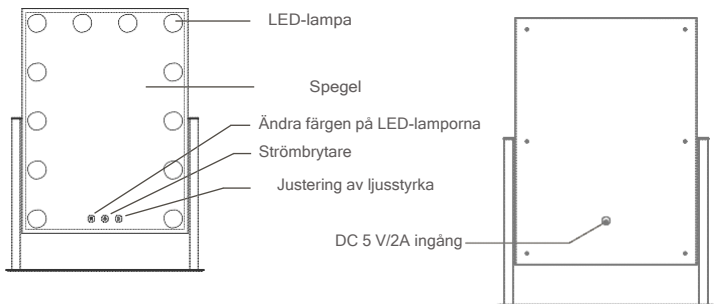

## TEKNISK INFORMATION

[Produktnamn] Lumio Lights Hollywood Sminkspegel

[Produktnummer] 102820762 & 102820764

[Material] Metall och glas

[LED-färgtemperatur] 6 500 / 3 500 K  $\pm$  500 K

[LED-ljusstyrka] 60–80 lm

[Strömkälla] USB 5 V / 1 A

[Nettovikt] 2 680  $\pm$  20 g

[Produktstorlek] 36 x 47,5 x 7,5 cm

[Förpackningsstorlek] 52 x 13,5 x 40 cm

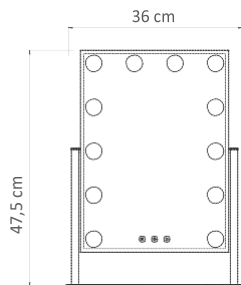

## EGENSKAPER



3 mm tjock miljövänlig glasspegel



Upplyst sminkspegel med energieffektiva LED-lampor



Du kan välja mellan varmt, naturligt och kallt ljus



Inbyggd beröringsbrytare



Kan svängas 360 grader



Strömmen matas med en USB

# FÖRPACKNINGSSINNEHÅLL



Sminkspegel



USB



Bruksanvisning

## ANVÄNDNING

- (1) Använd den ursprungliga USB 5 V/1 A kabeln.

Anslut kabeln till porten bakom spegeln.

- (2) Tryck  för att tända/släcka lamporna.

Ljusstyrkan är först 100 %.

- (3) Tryck  för att välja mellan varmt, naturligt och kallt ljus.

- (4) Tryck  länge för att justera ljusstyrkan.

- (5) Koppla ur nätadaptern när produkten inte används.

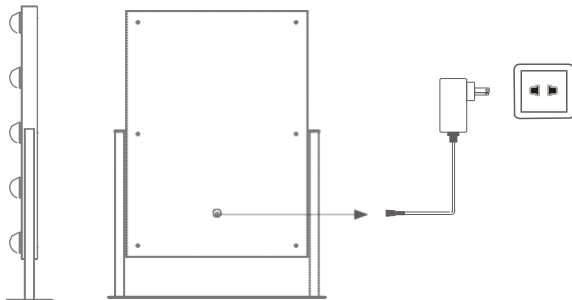
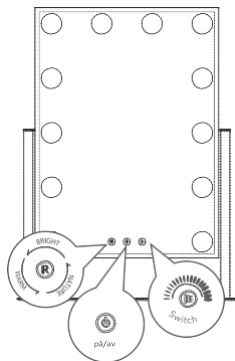



Made in China

## SÄKERHET

---

- ⚠ Läs dessa säkerhetsanvisningar noga innan du använder produkten.
  - ⚠ Demontera eller modifiera inte någon del av spegeln.
  - ⚠ Tryck lätt på beröringssensorn.
  - ⚠ Håll spegeln torr. Fuktighet minskar enhetens känslighet.
  - ⚠ Släck lamporna och dra ur nätadaptern innan rengöring. Använd glasrengöringsmedel. Se till att spegeln är helt torr innan du använder den.
  - ⚠ Stäng av och skydda mot direkt solljus när du förvarar spegeln under längre perioder och håll den utom räckhåll för barn.
  - ⚠ Innan du använder spegeln ska du kontrollera att nätadapterns spänning är tillräcklig.
  - ⚠ Vid brand eller explosion får du inte röra spegeln eller kasta den i elden.
  - ⚠ Sluta använda spegeln om något ovanligt inträffar.
- \* Vi förbehåller oss rätten att göra ändringar i produktdesign och specifikationer. Alla material som förtecknas är endast avsedda som referens. Ändringar i de tekniska specifikationerna meddelas inte separat.

**SUOMITRADING**

Suomi Trading Oy

Realparkinkatu 12, 37570 Lempäälä

[asiakaspalvelu@suomitradng.fi](mailto:asiakaspalvelu@suomitradng.fi)





# DESKTOP LED VANITY MIRROR

---

OPERATION MANUAL

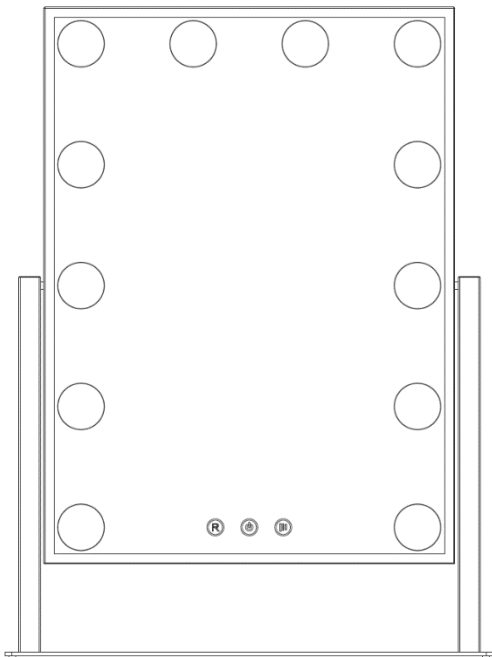

# ILLUSTRATE

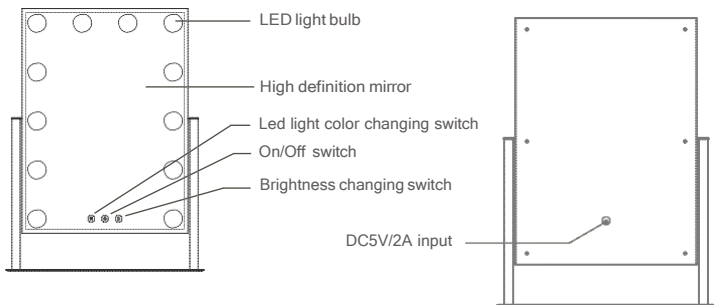

## SPECIFICATIONS

[Product Name] Lumio Lights Hollywood mirror

[Product number] 102820762 & 102820764

[Material] Metal+Glass

[LED Color Temperature] 6500K/3500K±500K

[LEDLM] 60-80LM

[Power Supply] USB 5V/1A

[Net Weight] 2680g±20g

[Product Size] 36\*47.5\*7.5cm

[Package Size] 52\*13.5\*40cm

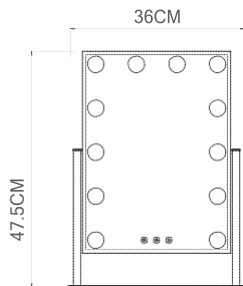

## SPECIAL FEATURE



3MM Thickness high definition eco-friendly glass mirror



This lighted makeup mirror uses built-in energy LED bulbs



Free to switch between warm, natural, and cold light



Built-in touch sensor switch



Can be rotated to 360 degree



Power supplied by a USB cable

## PACKING LIST

---



Desktop LED Vanity Mirror





USB Cable



Power Adapter

## OPERATING INSTRUCTIONS

---

- (1) Please use original USB cable 5V/1A, connect the appropriate adapter to the charging port on the back.
- (2) Press  switch to turn the light on/off. 100 %brightness when turned on.
- (3) Press  to switch between warm, natural and cold light.
- (4) Long pressing  to adjust the brightness.
- (5) Unplug the adapter when it is no used.

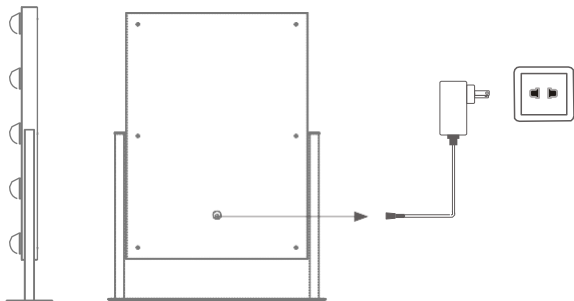
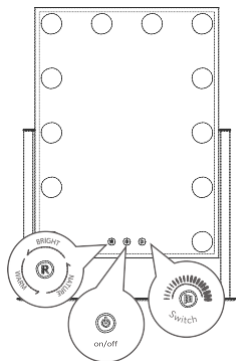



Made in China

## SAFETY INSTRUCTIONS

---

- ⓘ Please read these safety precautions carefully before using the product.
  - ⓘ Do not disassemble or alter the components of the mirror.
  - ⓘ Press the touch sensor gently.
  - ⓘ Keep the mirror dry. Moisture reduces the sensitivity of the appliance.
  - ⓘ Turn off and unplug the mirror before cleaning it. Use a glass cleaner. Make sure the mirror is completely dry before using it.
  - ⓘ Turn power off, avoid direct sunlight, when mirror is stored for a long period, and keep it away from children's reach.
  - ⓘ Before using your mirror, make sure that your charging device is adequate for its voltage.
  - ⓘ In case of a fire or explosion, do not touch or throw the mirror into the fire.
  - ⓘ Stop using your mirror if an abnormal situation occurs.
- \* We reserves the right of any modification of the product involving design and specification, all the materials here are for your reference only and are subject to the products you received. No further notice be given for any technical parameters changed.

**SUOMITRADING**

Suomi Trading Oy

Realparkinkatu 12, 37570 Lempäälä

[asiakaspalvelu@suomitrading.fi](mailto:asiakaspalvelu@suomitrading.fi)