

## HEED PRO 120cm taakkateline

Ohjeet



## Asennus

1. Tarkista asennusohjeista, että kaikki tarvittavat osat ovat mukana.
2. Puhdista auton katto ja ne tuotteen osat, jotka joutuvat kosketuksiin katon kanssa, ennen käyttöä ja säännöllisesti käytön aikana.
3. Käy läpi ja noudata huolellisesti asennusohjeita ja suositusluetteloa, jos sellainen on mukana. Asenna kattotelineet oikeassa järjestyksessä eli vaiheet 1, 2, 3 ja niin edelleen.
4. Jos asennusohjeissa ei anneta erityisiä asennuskohtia, pyri pitämään etummaisen ja taaimmaisen kattotelineen välillä vähintään 700 mm:n etäisyys.
5. Kun kuljetetaan pitkiä kuormia, kattotelineiden välisen etäisyyden on oltava vähintään 600 mm.
6. Tarkista joka kerta, kun kattotelineet asennetaan, että ne istuvat tukevasti katolla. Yritä työntää ja vetää kattotelineet irti, kun ne ovat lukittuja. Yritä myös vetää kiristimet irti katon reunasta. Jos onnistut liikuttamaan jotakin osaa kattotelineistä, ne on kiinnitettävä tiukemmin. Tämä testi on tehtävä säännöllisesti.
7. Joitakin kattoluukku- ja radioantennityyppejä ei voi käyttää, kun kattotelineet on asennettu.
8. Kattotelineet saa asentaa autoihin, joissa on lasikatto, ellei asennusohjeissa toisin mainita.
9. Valmistaja ei vastaa tuotteen virheellisestä asennuksesta tai käytöstä aiheutuneista omaisuusvahingoista tai omaisuuden menetyksestä.
10. Tuotteeseen ei saa tehdä muutoksia.
11. Ota yhteyttä jälleenmyyjään, jos sinulla on kysyttävää tuotteiden toiminnasta ja rajoituksista. Tutustu kaikkiin ohjeisiin ja takuutietoihin huolellisesti.

## Kuormaaminen

1. Asennusohjeissa mainittua enimmäiskuormaa ei saa ylittää. Ajoneuvon valmistajan kattokuormarajoitukset ovat kuitenkin etusijalla. Kaikissa tapauksissa näistä rajoituksista alhaisempi on se, jota sovelletaan.  
**Kattokuorma = kattotelineiden paino + mahdollisesti asennetut kattotelineiden lisävarusteet + itse kuorman paino.**
2. Kuorma ei saa ylittää merkittävästi kattotelineiden leveyttä, ja se on aina levitettävä tasaisesti kattotelineille ja mahdollisimman matalalla painopisteellä.
3. Maksimikuorma koskee sekä liikkeessä olevaa että pysäköityä ajoneuvoa.
4. Kun kuljetetaan useita lainelautoja, niitä ei saa asettaa vierekkäin vaan päällekkäin.
5. Kun kuljetetaan lainelautoja ja muita pitkiä esineitä, ne on kiinnitettävä sekä ajoneuvon etu- että takaosaan.
6. Sukset on kuljetettava siten, että niiden kärjet osoittavat ajoneuvon takaosaan.
7. Kaikki kuorman irtonaiset tai irrotettavat osat, kuten pyörän lastenistuimet, rengaspumput yms on irrotettava ennen lastausta.
8. Kuorma on kiinnitettävä huolellisesti. Joustavia liinoja ei saa käyttää.
9. Kuorman kiinnitys on tarkistettava lyhyen matkan jälkeen ja sen jälkeen sopivin väliajoin. Kiristä kuorman kiinnityshihnat aina tarvittaessa.

HUOMAA! Tarkista aina kuorman kiinnitys.

## Ajo-ominaisuudet ja määräykset

1. Ajonopeus on aina sovitettava kuljettavan kuorman ja senhetkisten ajo-olosuhteiden, kuten tien tyyppin ja laadun, tuuliolosuhteiden, liikennemäärän ja voimassa olevien nopeusrajoitusten mukaan.
2. Ajoneuvon nopeus on aina sovitettava kuljettavan kuorman ja senhetkisten ajo-olosuhteiden, kuten tietyyppin, tien laadun, tuuliolosuhteiden, liikennemäärän ja voimassa olevien nopeusrajoitusten mukaan, mutta se ei saa missään tapauksessa ylittää 130 km/h. Voimassa olevia nopeusrajoituksia ja muita liikennesääntöjä on aina noudatettava.
3. Aja hitaasti hidastetöyssyjen yli, enimmäisnopeus 10 km/h.
4. Huomaa, että ajoneuvon kokonaiskorkeus kasvaa, kun ajoneuvossa on pystykuormia.
5. Ajoneuvon ajo-ominaisuudet ja jarrutusikäytyminen muuttuvat, ja sen alttius sivutuulelle kasvaa, kun katolla kuljetetaan kuormaa.
6. Lukolla varustetut tuotteet on aina lukittava kuljetuksen ajaksi.
7. Maastoajo on sallittu vain kattotelineillä, joihin ei ole kiinnitetty kuormaa tai lisävarusteita.
8. Sopeuta nopeutesi tieolosuhteisiin ja kuljetettavaan kuormaan. Tarkista kattotelineiden kireys usein, erityisesti kun ajat epätasaisilla teillä.

## Ylläpito

1. Tarkista ja vaihda kuluneet tai vialliset osat.
2. Kattotelineet on puhdistettava ja huollettava, erityisesti talvella.
3. Ruuvit, mutterit ja lukot (jos ne on asennettu) on voideltava säännöllisin väliajoin.
4. Kun tuotetta ei käytetä, se on poistettava katolta.
5. Kun tuote on irrotettu ajoneuvosta, pidä kaikki irtonaiset osat tallessa.

**SUOMITRADING.fi**

Suomi Trading Oy  
RealParkinkatu 12, 37570 Lempäälä  
asiakaspalvelu@suomitradng.fi

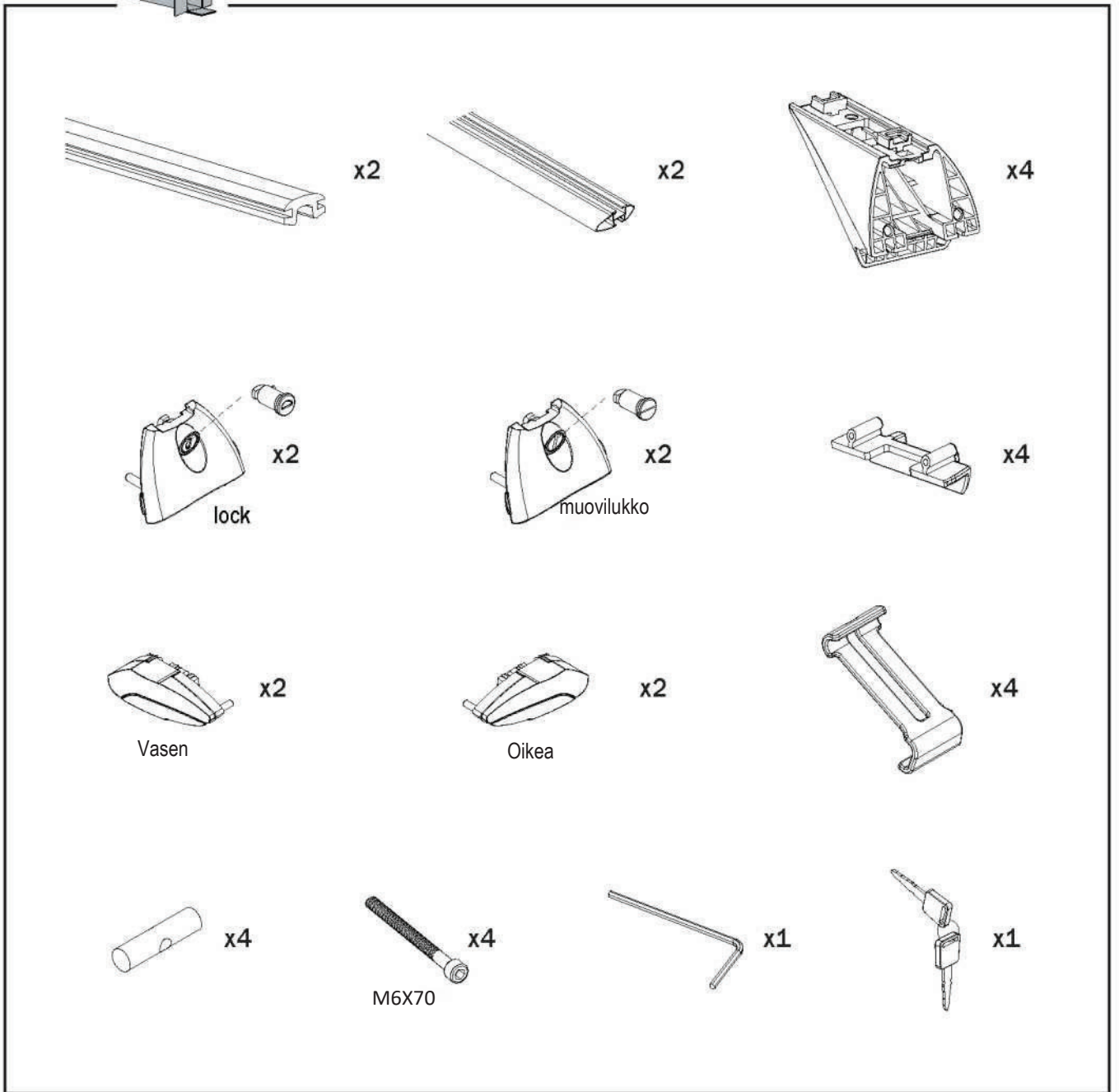
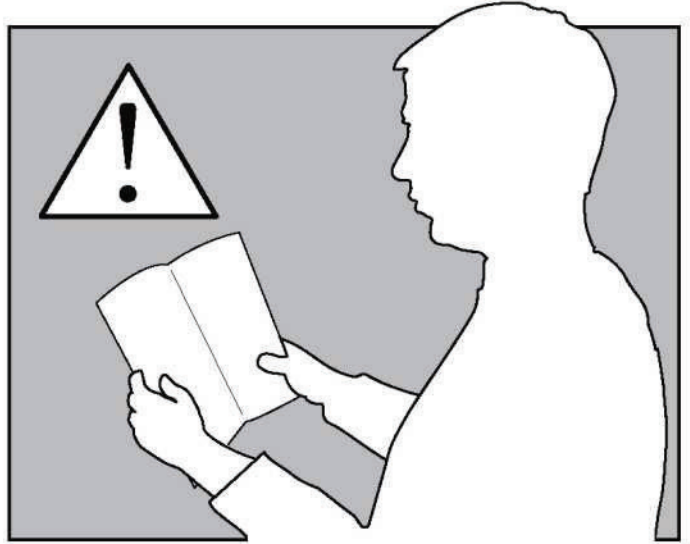
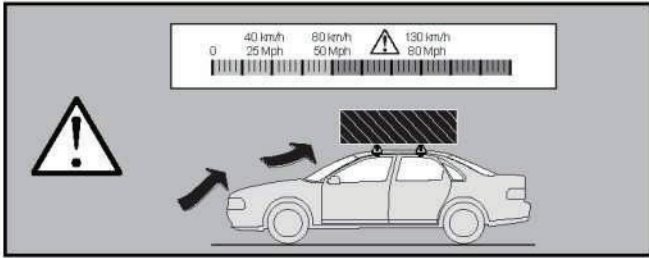
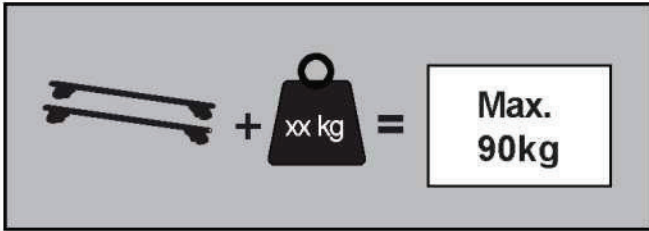

1

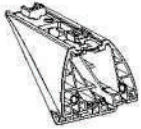

x4



x4

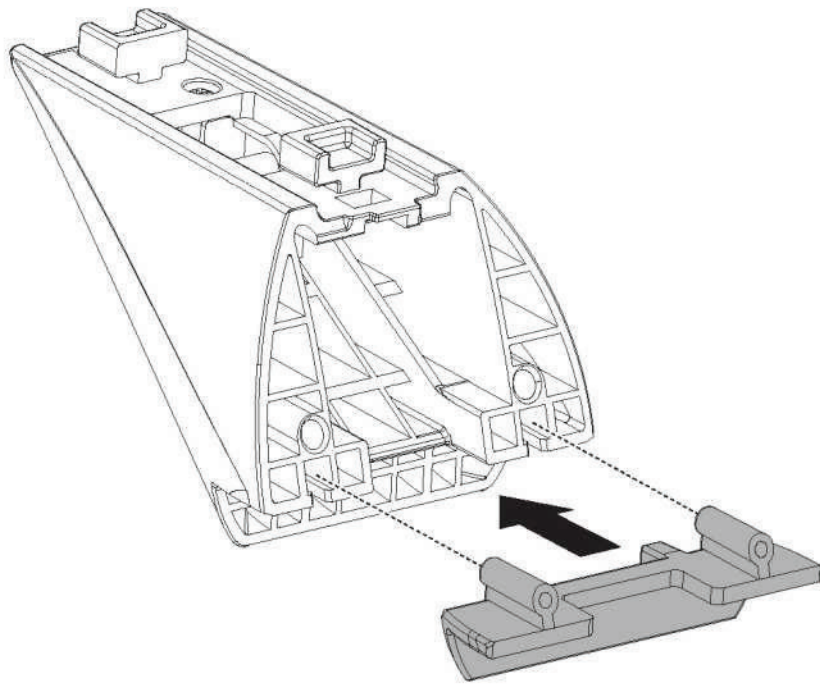

2

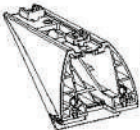

x4



x4



x4

M6X70



x4

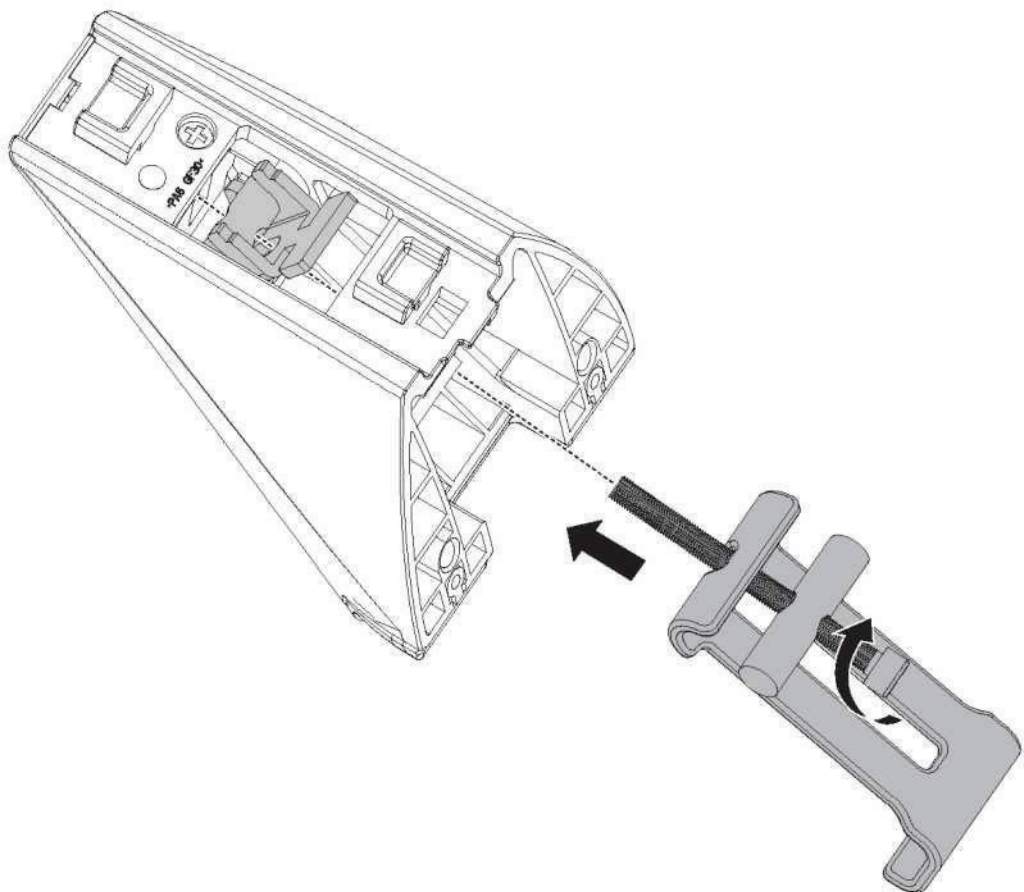

3

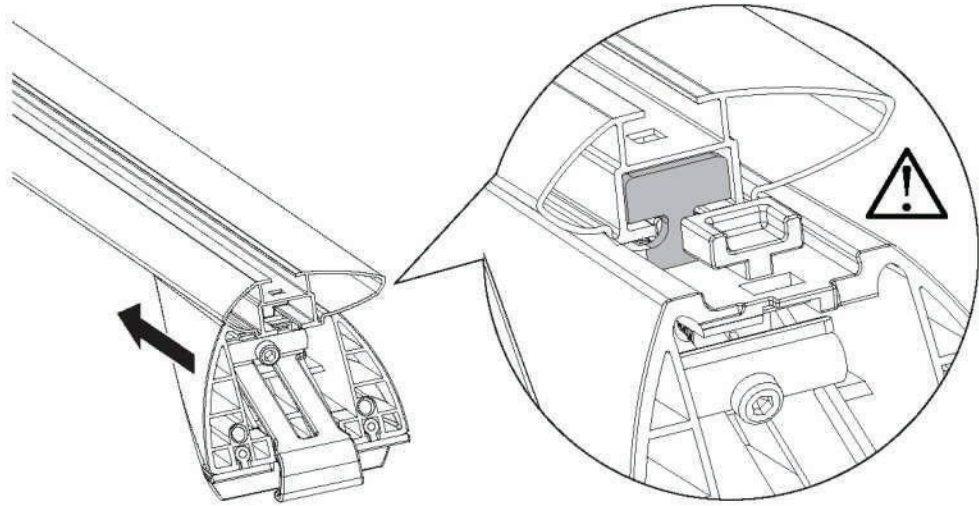
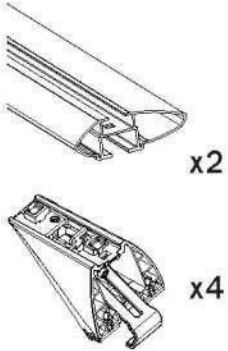

4



5

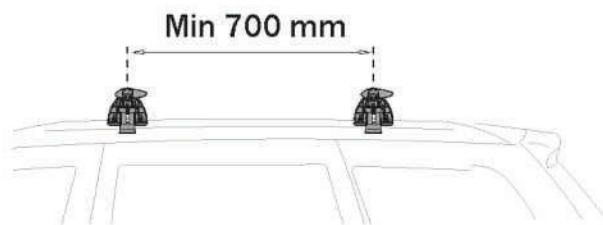
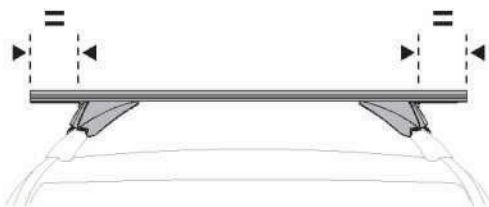
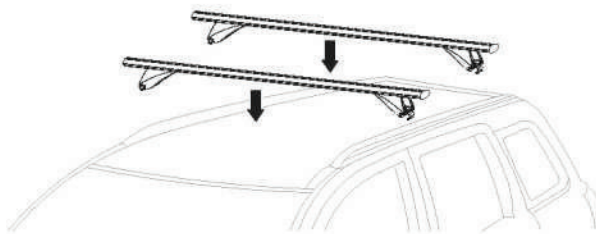

6

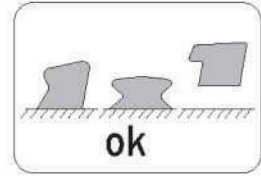
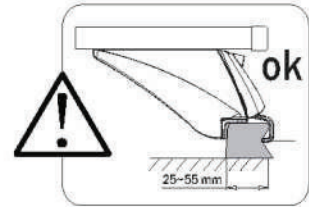
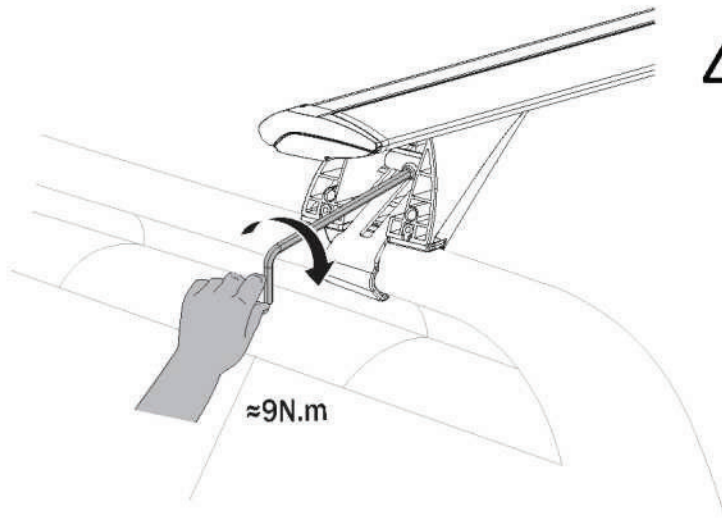

7

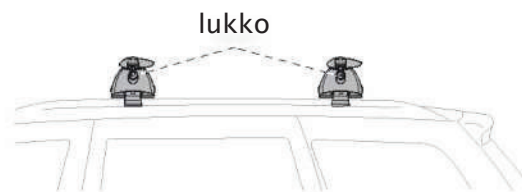
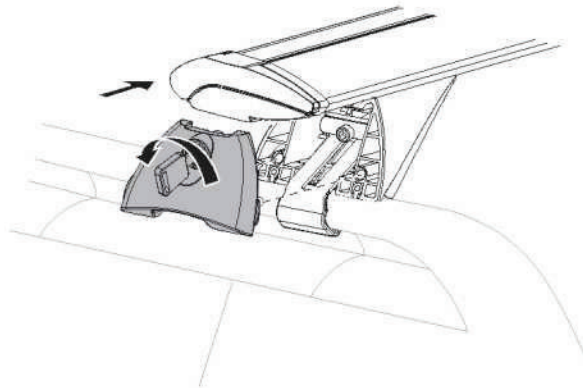
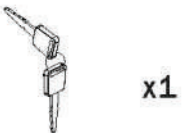
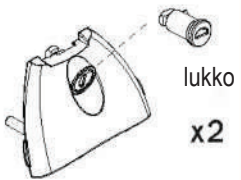

LISÄVARUSTEET

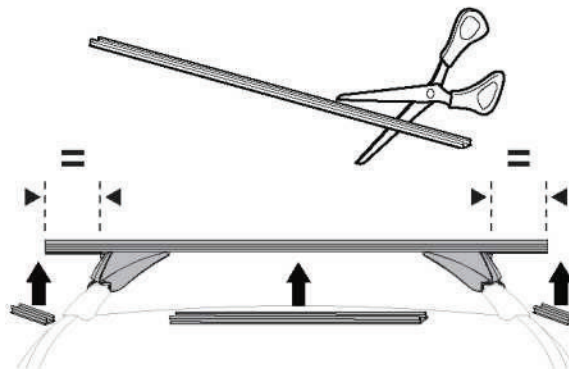

8

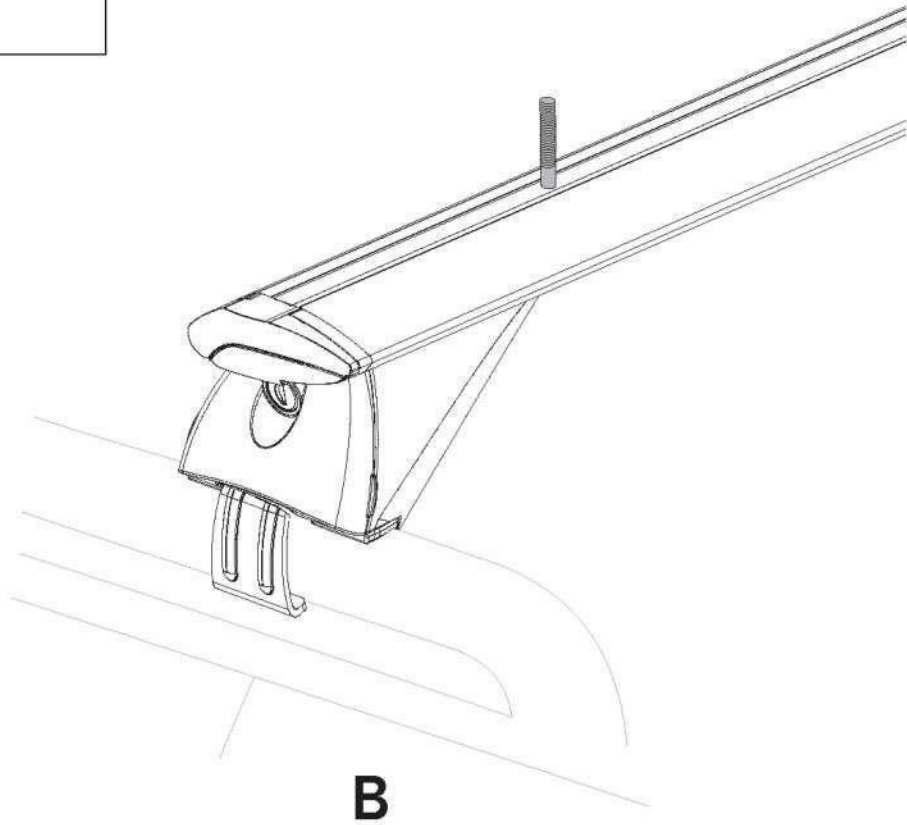
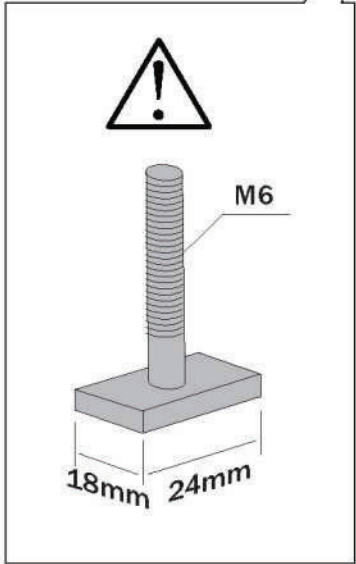
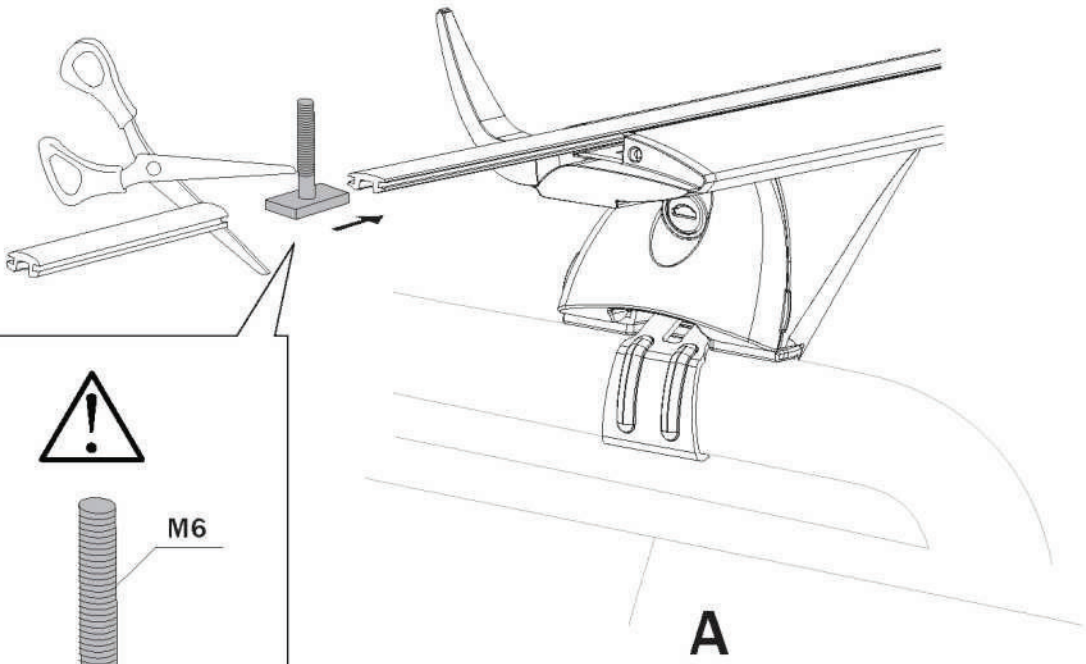

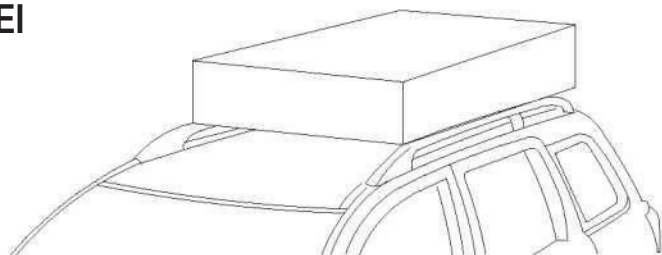
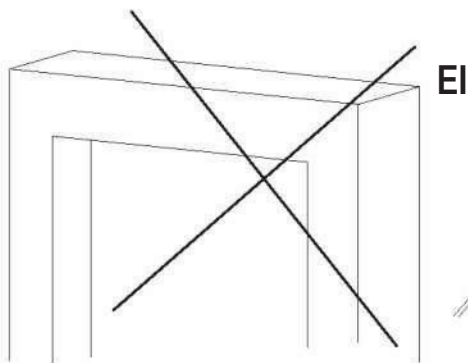
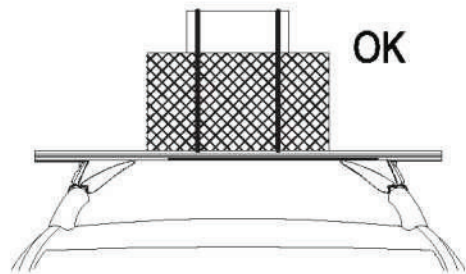
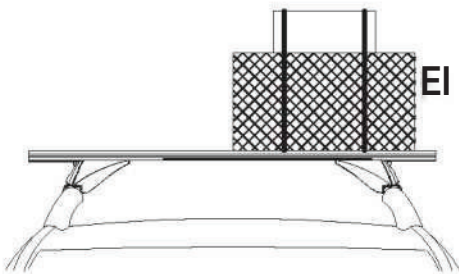
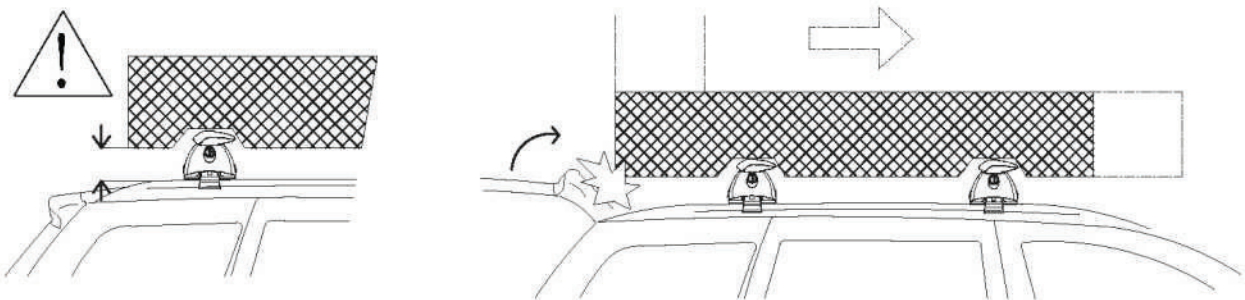
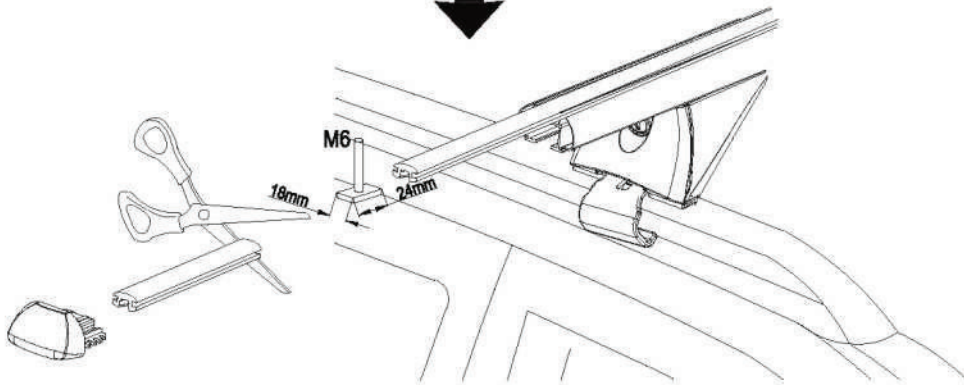
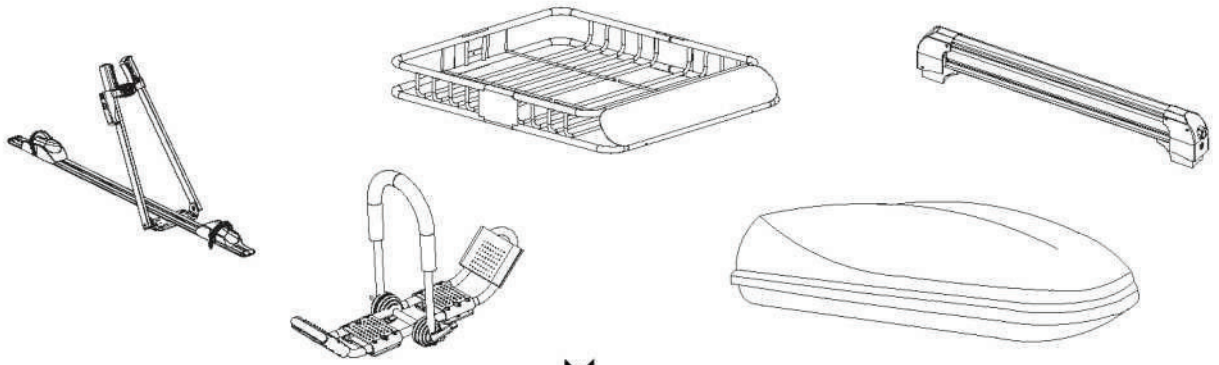



*heed*

# HEED PRO 120cm taakkateline

Anvisningar



## Installation

1. Kontrollera installationsinstruktionerna för att se till att alla nödvändiga delar ingår.
2. Rengör biltaket och de delar av produkten som kommer i kontakt med taket före användning och regelbundet under användning.
3. Läs och följ noga installationsanvisningarna och listan över rekommendationer, om en sådan finns med. Montera takrätten i rätt ordning, dvs. steg 1, 2, 3 och så vidare.
4. Om inte särskilda monteringspunkter anges i monteringsanvisningarna ska du sträva efter att hålla ett minsta avstånd på 700 mm mellan de främre och bakre takrätten.
5. Vid transport av långa laster måste avståndet mellan takrätten vara minst 600 mm.
6. Varje gång du monterar takrätten ska du kontrollera att de sitter ordentligt på taket. Försök att skjuta och dra loss takrätten när de är låsta. Försök också att dra fästena bort från takets kant. Om du lyckas flytta någon del av takrätten måste de dras åt. Detta test bör göras regelbundet.
7. Vissa typer av takluckor och radioantennor kan inte användas när takrätten är installerade.
8. Takrätten kan installeras på bilar med glastak, om inget annat anges i monteringsanvisningarna.
9. Tillverkaren är inte ansvarig för skador på eller förlust av egendom som orsakats av felaktig installation eller användning av produkten.
10. Inga ändringar får göras i produkten.
11. Kontakta din återförsäljare om du har några frågor om hur produkterna fungerar och vilka begränsningar de har.  
Läs alla instruktioner och garantiinformation noggrant.

## Lastning

1. Den maximala belastning som anges i monteringsanvisningarna får inte överskridas. Fordonstillverkarens taklastgränser har dock företräde. I samtliga fall är det den lägsta av dessa gränser som gäller. **Taklast = takrättens vikt + eventuella installerade takrättstillbehör + själva lastens vikt.**
2. Lasten får inte vara betydligt större än takrättens bredd och måste alltid vara jämnt fördelad över takrätten och med lägsta möjliga tyngdpunkt.
3. Den maximala belastningen gäller både parkerade fordon och fordon i rörelse.
4. När flera surfbrädor transporteras får de inte placeras sida vid sida utan ovanpå varandra.
5. När surfbrädor och andra långa föremål transporteras måste de fästas både fram och bak på fordonet.
6. Skidor måste transporteras med spetsarna riktade mot fordonets bakre del.
7. Alla lösa eller löstagbara delar av lasten, t.ex. barnstolar, däckpumpar, fenor etc., måste avlägsnas före lastning.
8. Lasten måste säkras noggrant. Flexibla dukar får inte användas.
9. Lasten ska kontrolleras efter en kort sträcka och därefter med lämpliga intervaller. Dra alltid åt lastlinorna om det behövs.

OBSERVERA! Kontrollera alltid att lasten är säkrad.

## Köregenskaper och bestämmelser

1. Körhastigheten måste alltid anpassas till den last som ska transporteras och de aktuella körförhållandena, såsom vägens typ och kvalitet, vindförhållanden, trafikvolym och gällande hastighetsbegränsningar.
2. Fordonets hastighet måste alltid anpassas till den last som transporteras och till de aktuella körförhållandena, såsom vägtyp, vägkvalitet, vindförhållanden, trafikvolym och gällande hastighetsbegränsningar, men får under inga omständigheter överstiga 130 km/h. Hastighetsbegränsningar och andra gällande trafikregler måste alltid respekteras.
3. Kör långsamt över farthinder, högsta hastighet 10 km/h.
4. Observera att fordonets totala höjd ökar när vertikala laster förekommer.
5. Fordonets köregenskaper och bromsbeteende förändras, och dess känslighet för sidovindar ökar när en last bärs på taket.
6. Produkter som är försedda med lås måste alltid vara låsta under transport.
7. Terrängkörning är endast tillåten med takrätten utan last eller tillbehör.
8. Anpassa hastigheten till vägförhållandena och den last du bär. Kontrollera ofta att takrätten är spända, särskilt när du kör på ojämna vägar.

## Underhåll

1. Kontrollera och byt ut slitna eller felaktiga delar.
2. Takrätten måste rengöras och underhållas, särskilt på vintern.
3. Skruvar, muttrar och lås (om sådana finns) måste smörjas med jämna mellanrum.
4. När produkten inte används måste den tas bort från taket.
5. När produkten har avlägsnats från fordonet ska du spara alla lösa delar.

**SUOMITRADING.FI**

Suomi Trading Oy  
RealParkinkatu 12, 37570 Lempäälä  
asiakaspalvelu@suomitrading.fi

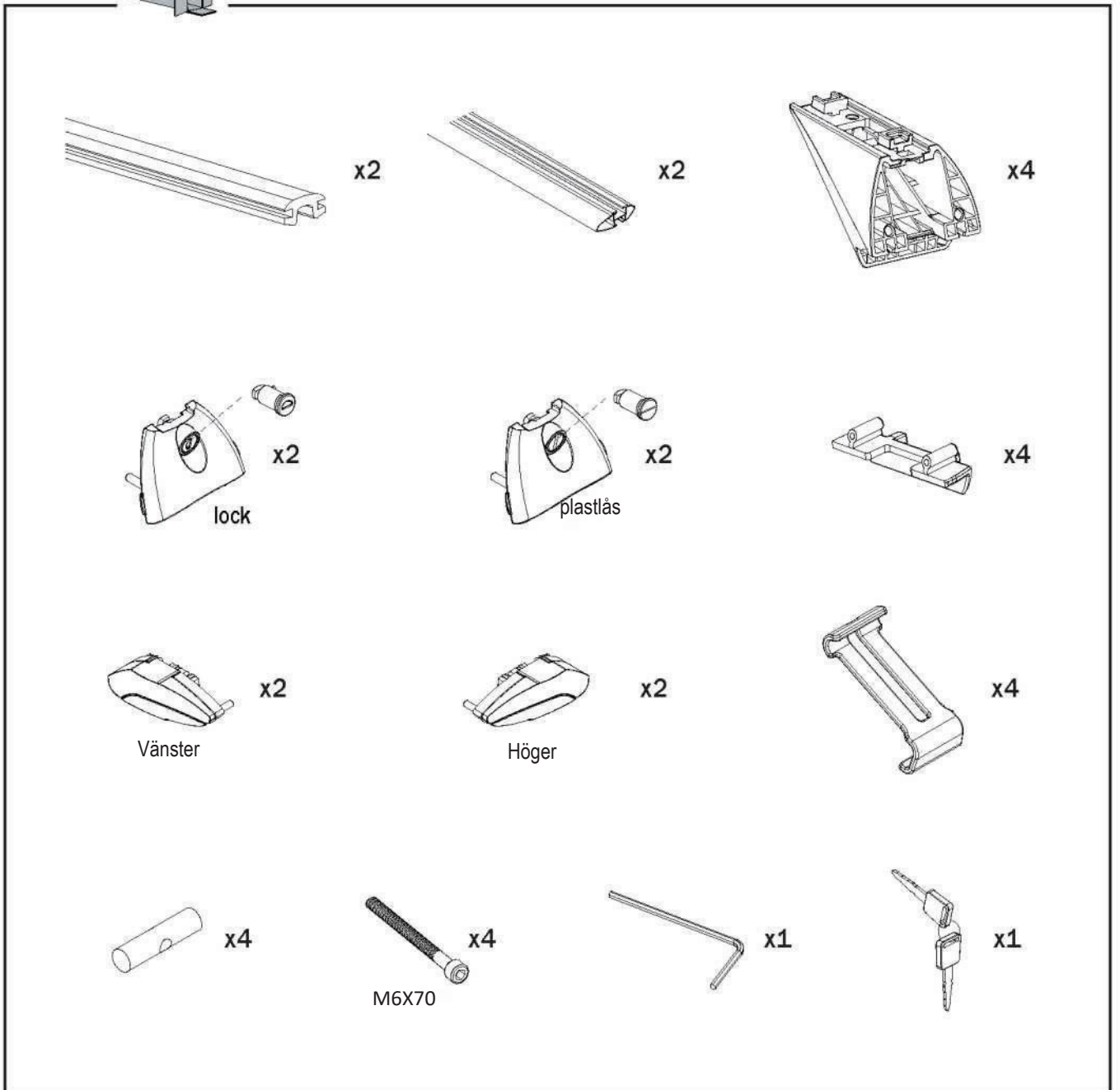
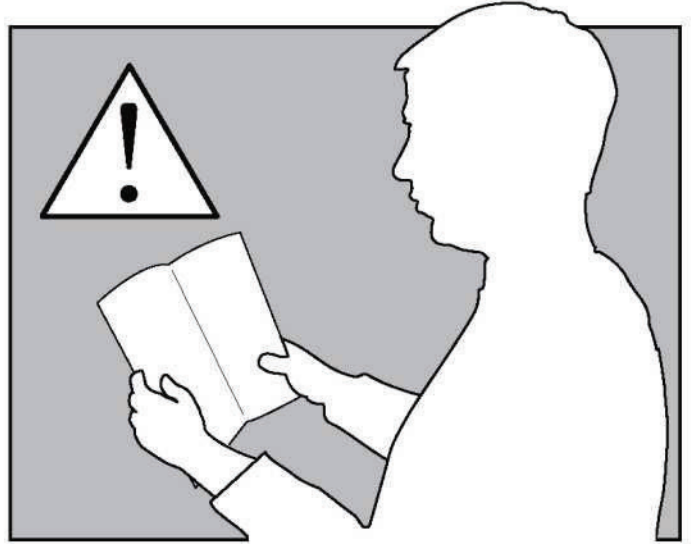
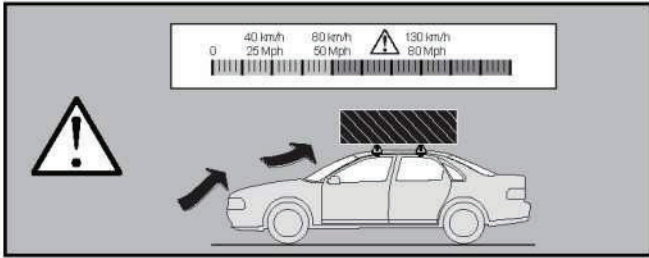
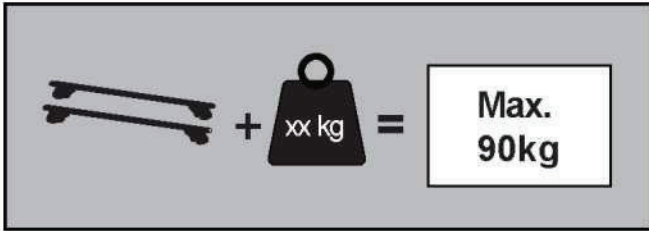

1

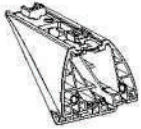

x4



x4

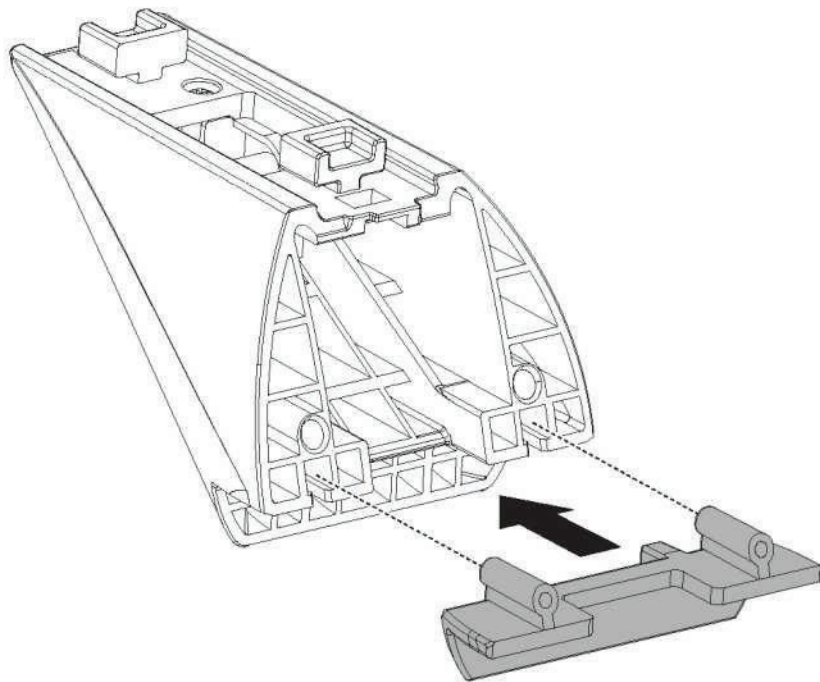

2

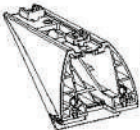

x4



x4



x4

M6X70



x4

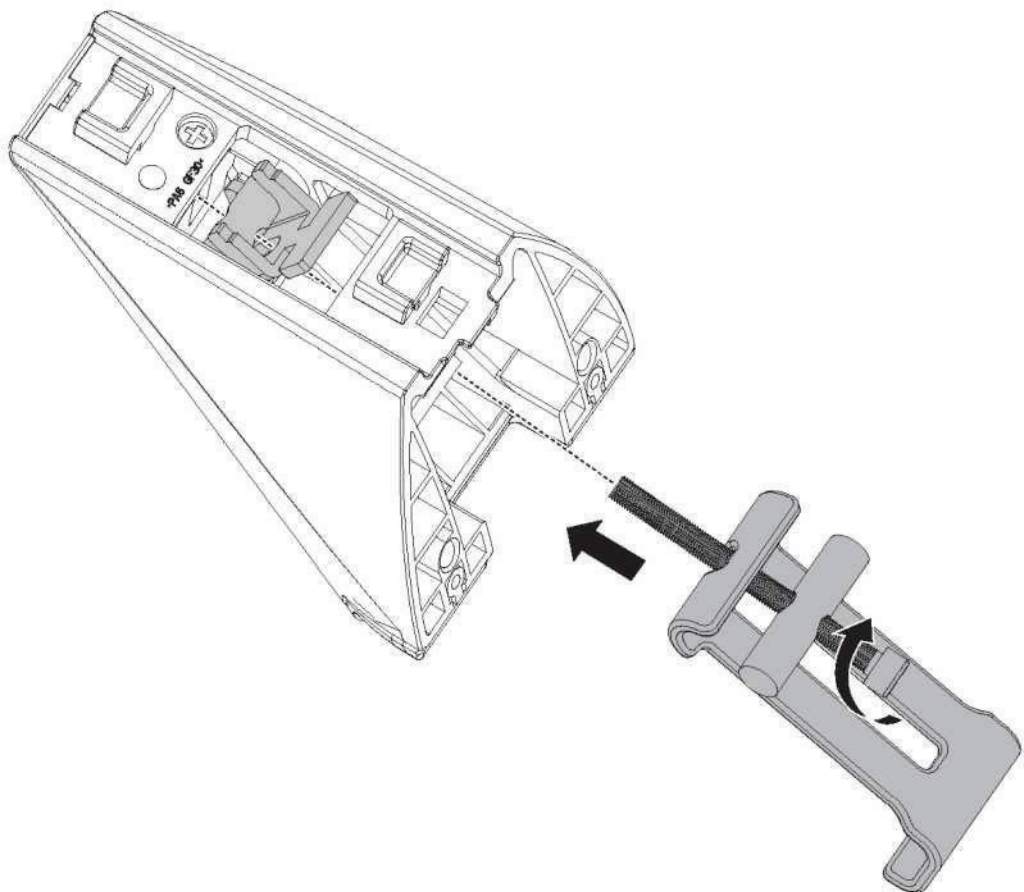

3

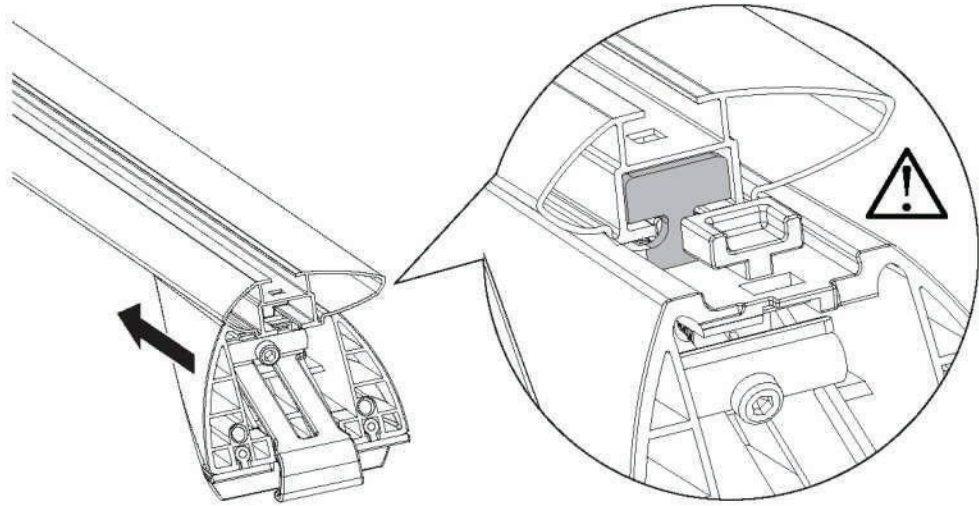
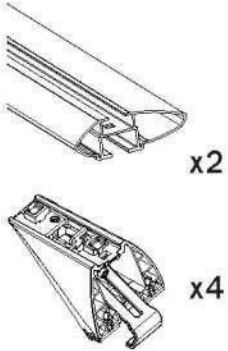

4



5

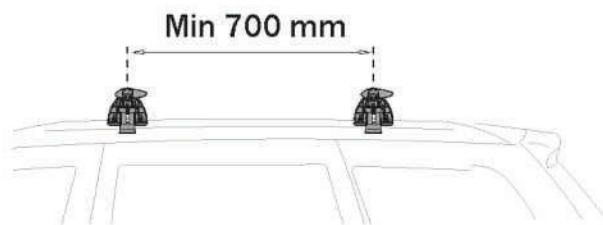
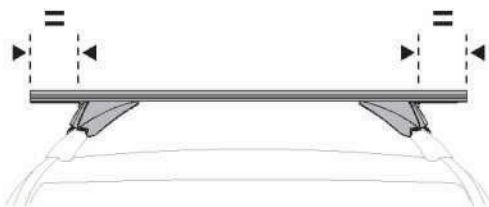
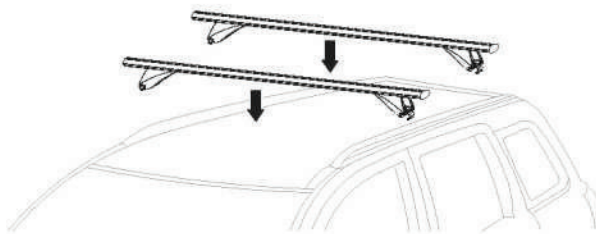

6

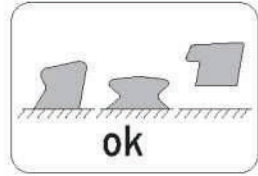
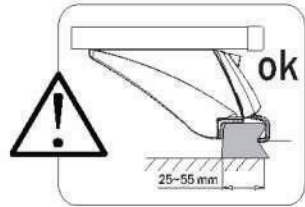
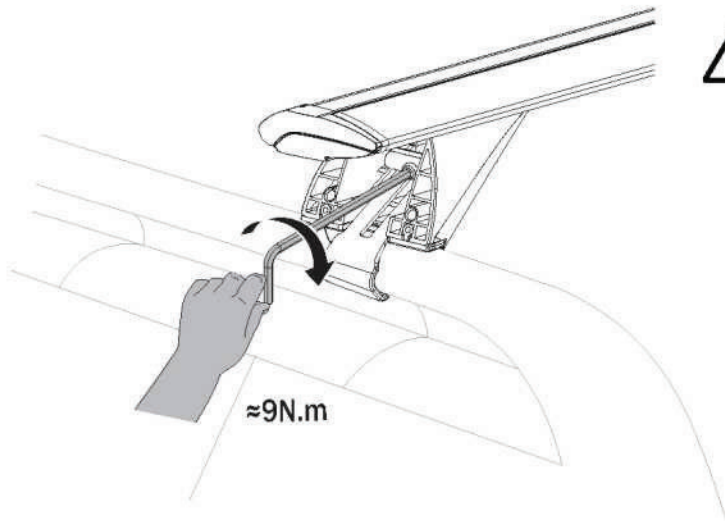

7

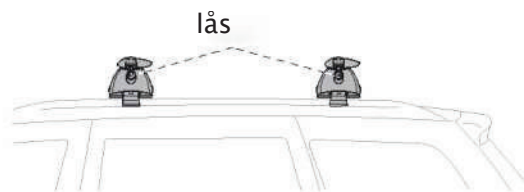
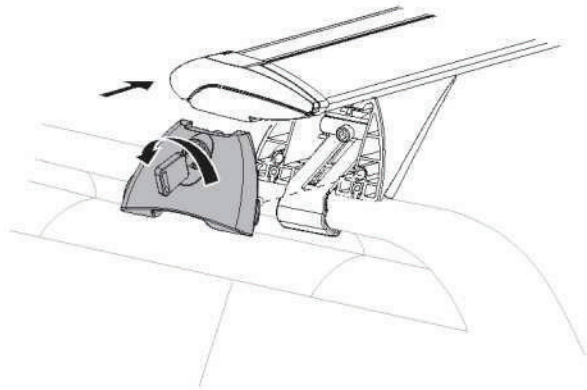
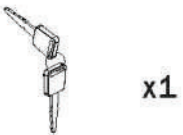
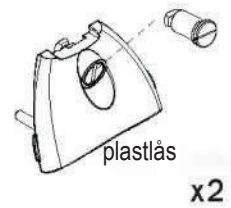
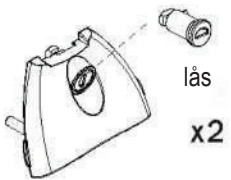

TILLBEHÖR

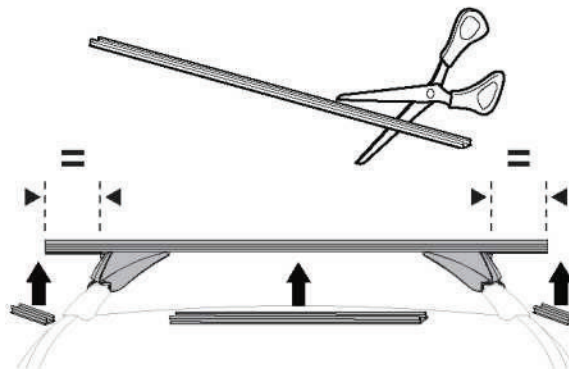

8

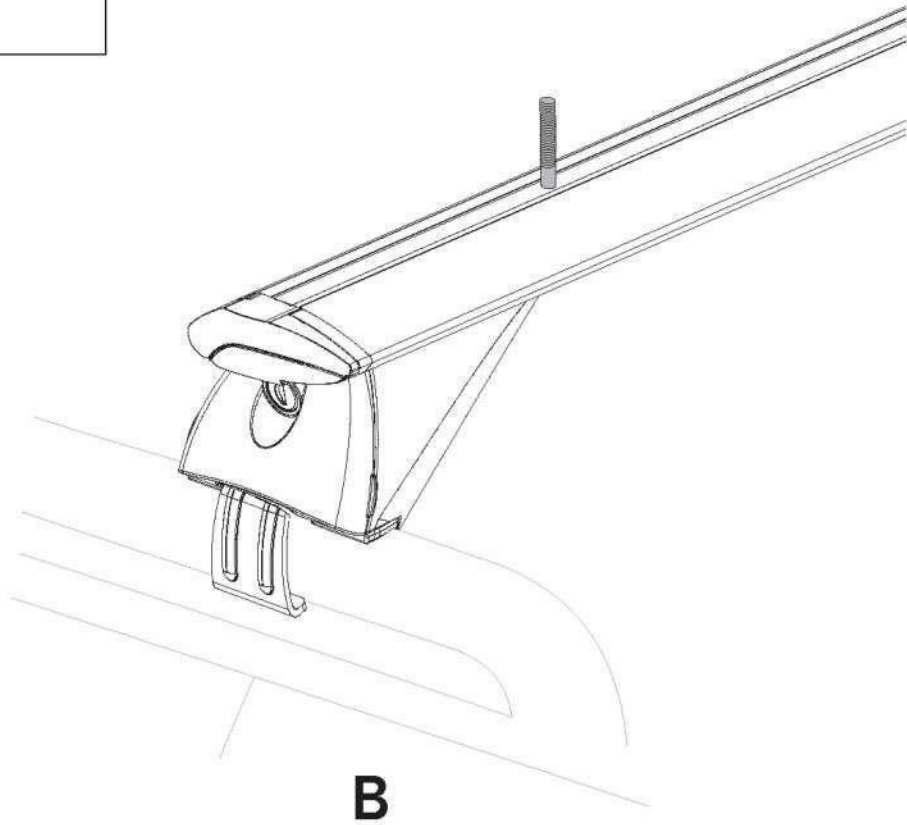
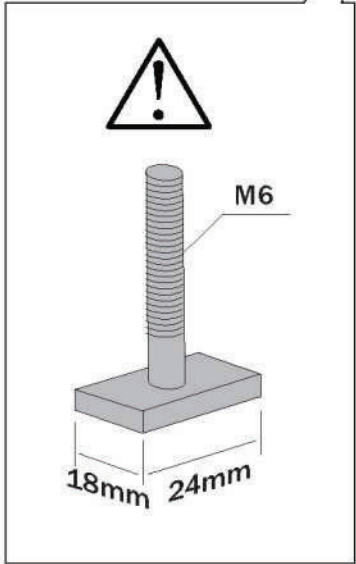
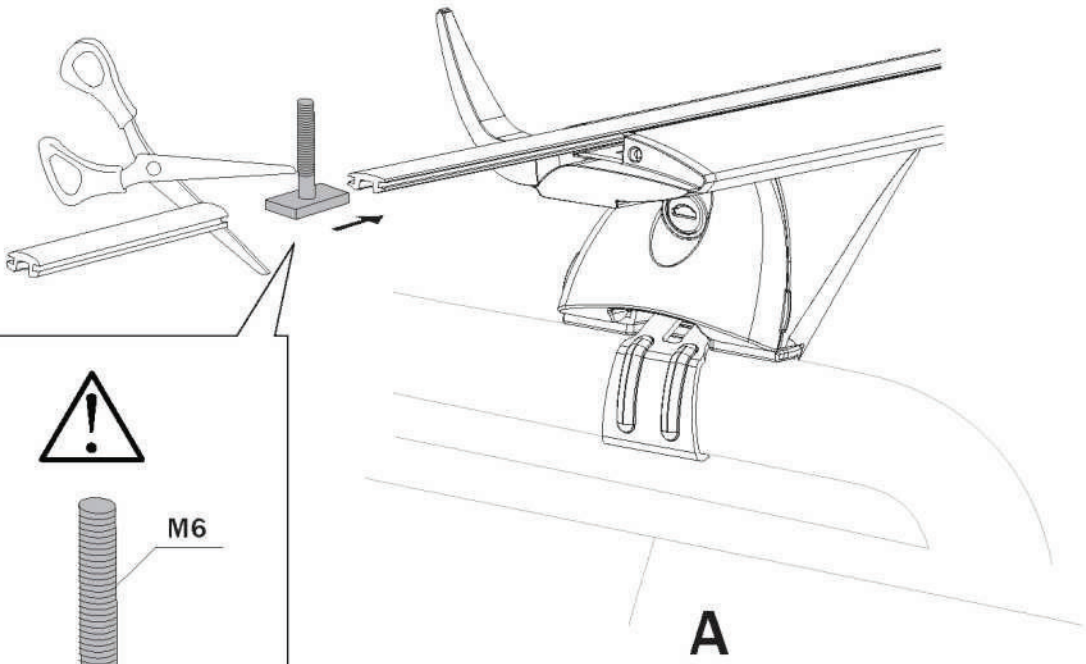

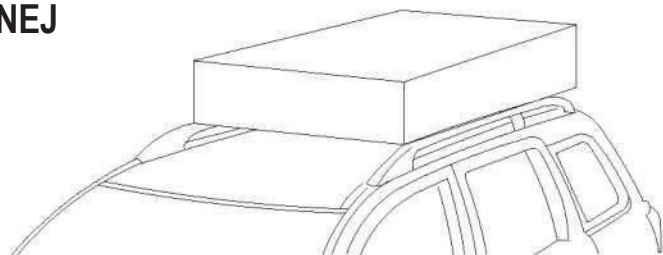
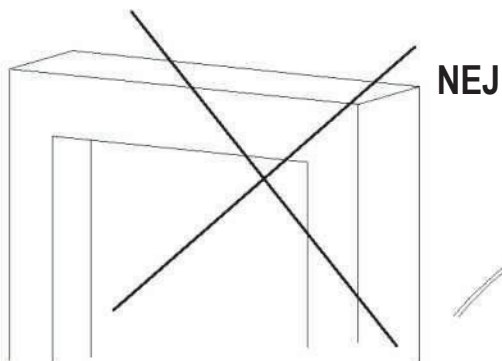
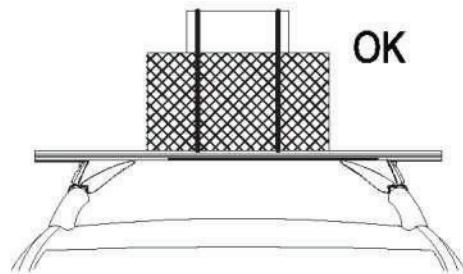
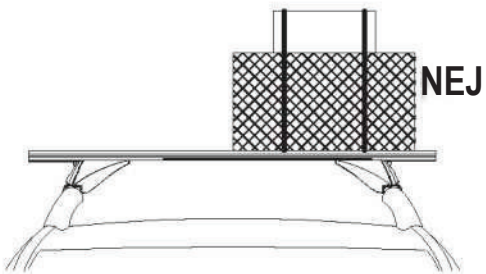
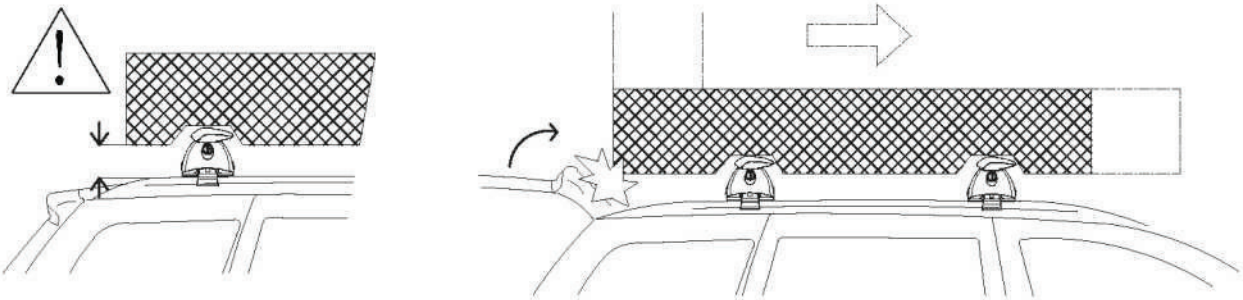
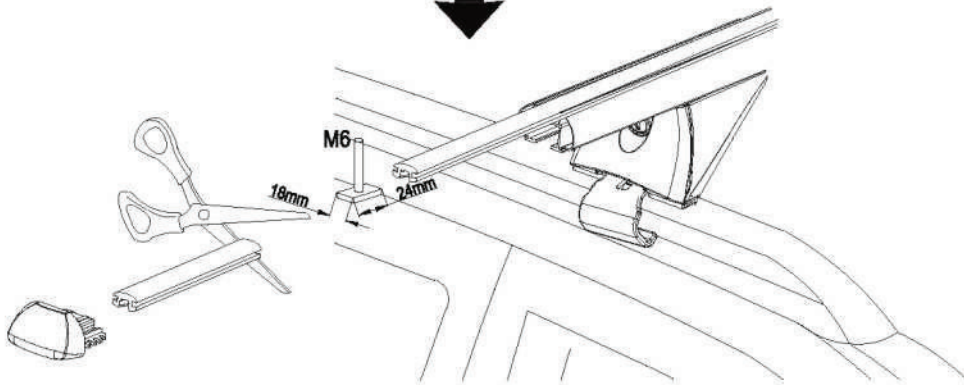
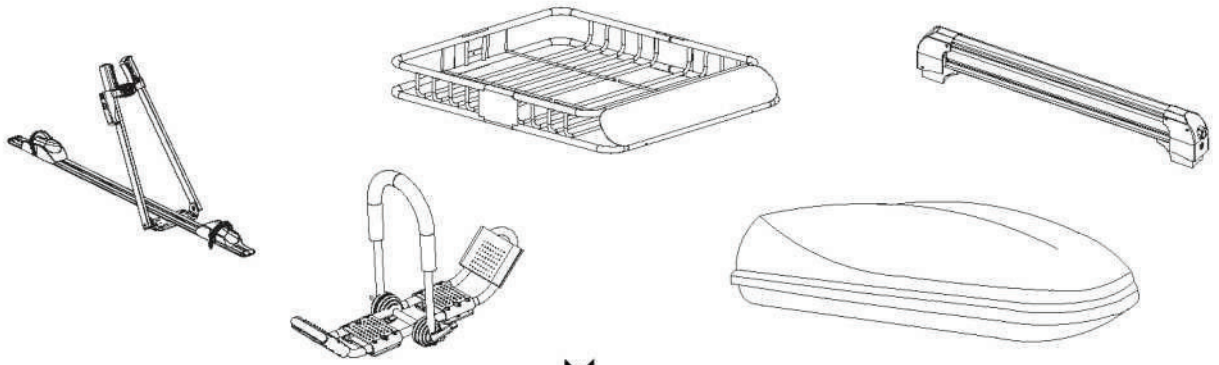



# *heed*

## HEED PRO 120cm roof rack

Instructions



## Fitting

1. Check with the assembly instructions that all the necessary parts are present.
2. Clean the car roof and those parts of the product that come into contact with the roof before and regularly during use.
3. Go through and carefully follow the assembly instructions and the recommendation list, if one is included. Then fit the unit in the correct sequence, that is to say 1, 2, 3 and so on.
4. If no special fitting positions are given in the assembly instructions, try to maintain a minimum distance of 700 mm between the load carrier bars.
5. When carrying long loads, the distance between the load carrier bars should not be less than 600 mm.
6. Every time the unit is fitted, check that the load carrier is sitting securely on the roof. Try to push and pull the carrier out of its locked position. Try also to pull out the tensioning tabs from the roof edge. If you manage to move any part of the unit, the load carrier must be secured more firmly. This test should be carried out regularly.
7. Some types of sunroof and radio antenna cannot be used when the carrier is fitted.
8. The roof rack is permitted to be assembled on cars with glass roof, unless otherwise is specified in mounting instruction.
9. The manufacturer can not be held responsible for personal damages of property or lost of fortune caused by incorrect mounting or use of the product.
10. No modifications to the product are permitted.
11. Consult with your dealer if you have any questions regarding the operations and limits of the products. Review all instructions and warranty information carefully.

## Loading

1. The maximum load specified in the assembly instructions is not to be exceeded. However, this limit is always subordinate to the maximum load recommended by the manufacturer of the car itself. It is always the lower maximum recommended load that applies. **Max. roof load = load carrier weight + any fitted carrier accessories + the weight of the load itself.**
2. The load may not significantly exceed the load carrier's width, and it should always be spread evenly across the load carrier and with the lowest possible centre of gravity.
3. Maximum load applies to driving as well as parked vehicle.
4. When several surfboards are being carried, they should not be placed beside each other but instead one on top of the other.
5. When carrying surfboards and other long items, these shall be secured both at the front and the rear of the vehicle.
6. Skis must be carried with their pointed ends facing the rear of the vehicle.
7. All loose or removable parts of the load such as bike child seats, tyre pumps, fins and so on should be taken off prior to loading.
8. The load should be thoroughly secured. Elastic bungees are not to be used.
9. The load's security should be checked after a short distance, and there after at suitable intervals. Tighten the load's securing straps whenever necessary.

NOTE! Always check the load's attachment security.

## Driving properties and regulations

1. Road speed should always be adjusted to suit the load being carried and the current driving conditions, such as road type and quality, wind conditions, traffic intensity and applicable speed limits.
2. The vehicle's speed must always be adjusted to the load being carried and the current driving conditions, such as the road type, road quality, wind conditions, traffic intensity and applicable speed limits, but must under no circumstances exceed 130 km/h. Applicable speed limits and other traffic regulations must always be observed.
3. Drive slowly over speed bumps, maximum speed 10 km/h.
4. Note that the vehicle's total height increases when upright loads are carried.
5. The vehicle's driving characteristics and braking behaviour change and its vulnerability to side-winds increases when a load is carried on the roof.
6. Products fitted with a lock should always be locked during transport.
7. Off-road driving is only approved for roof rack without load or accessories attached.
8. Adapt your speed to the conditions of the road and load being carried, check tension of load carrier frequently, especially when travelling on rough roads.

## Maintenance

1. Check and replace worn-out or defective parts.
2. The load carrier should always be cleaned and maintained, especially in the winter.
3. Screws, nuts and locks (if fitted) should be lubricated at regular intervals.
4. When not in use, the product should be removed from the vehicle.
5. When the product is removed from the vehicle, all loose parts should be stored safely.

**SUOMITRADING.fi**

Suomi Trading Oy  
RealParkinkatu 12, 37570 Lempäälä  
asiakaspalvelu@suomitradng.fi

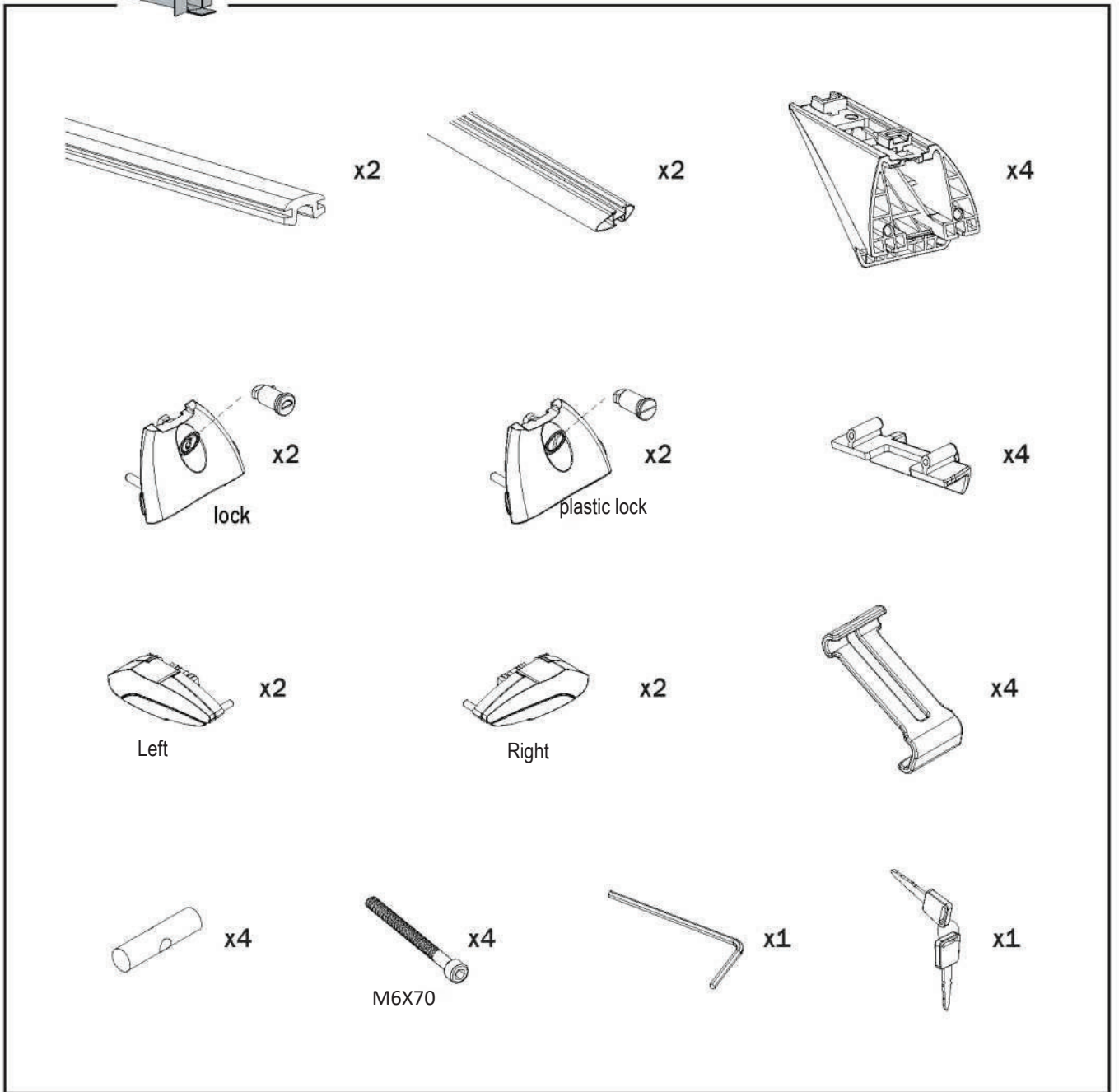
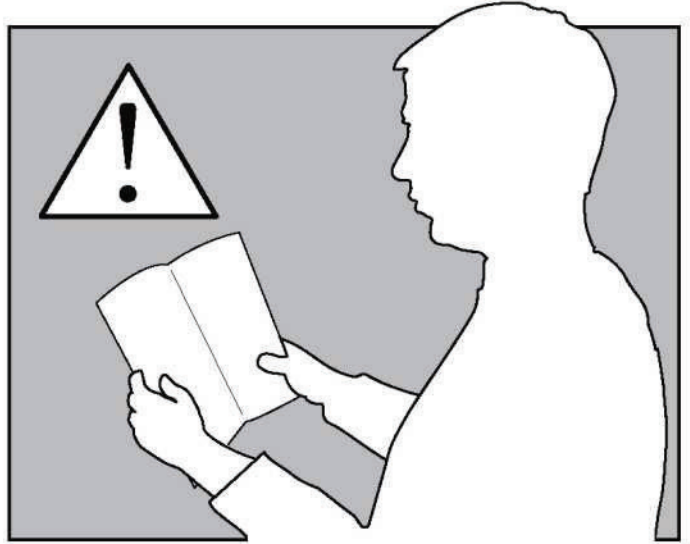
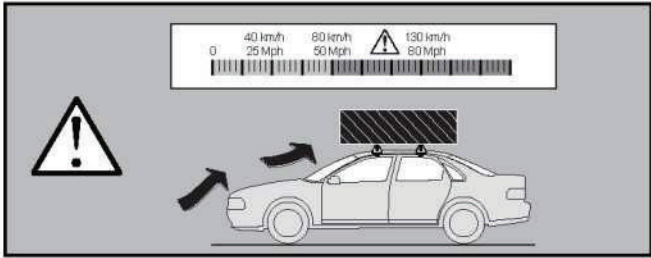
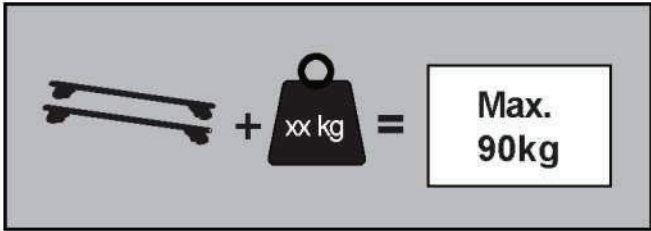

1

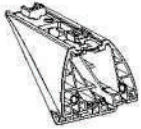

x4



x4

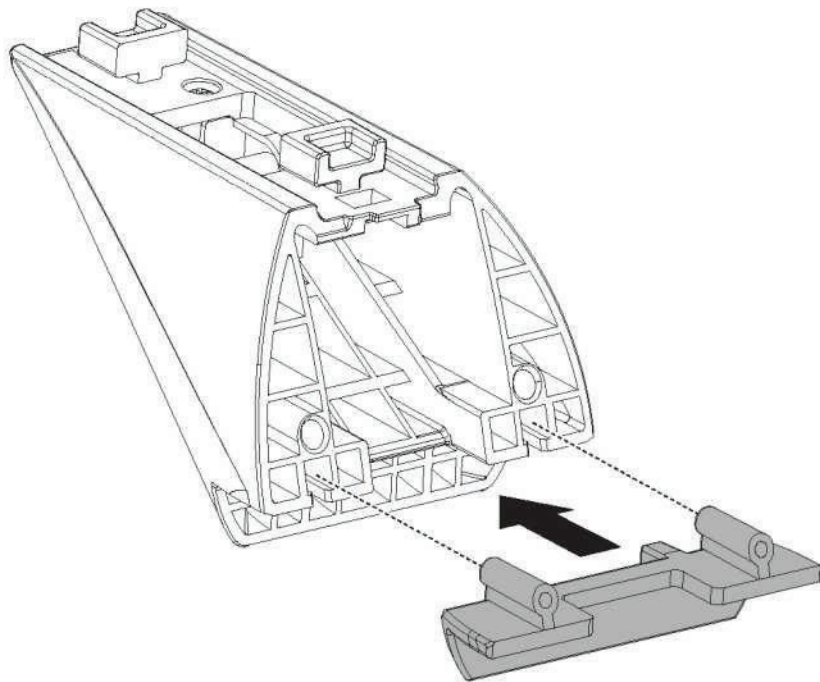

2

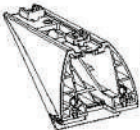

x4



x4



x4

M6X70



x4

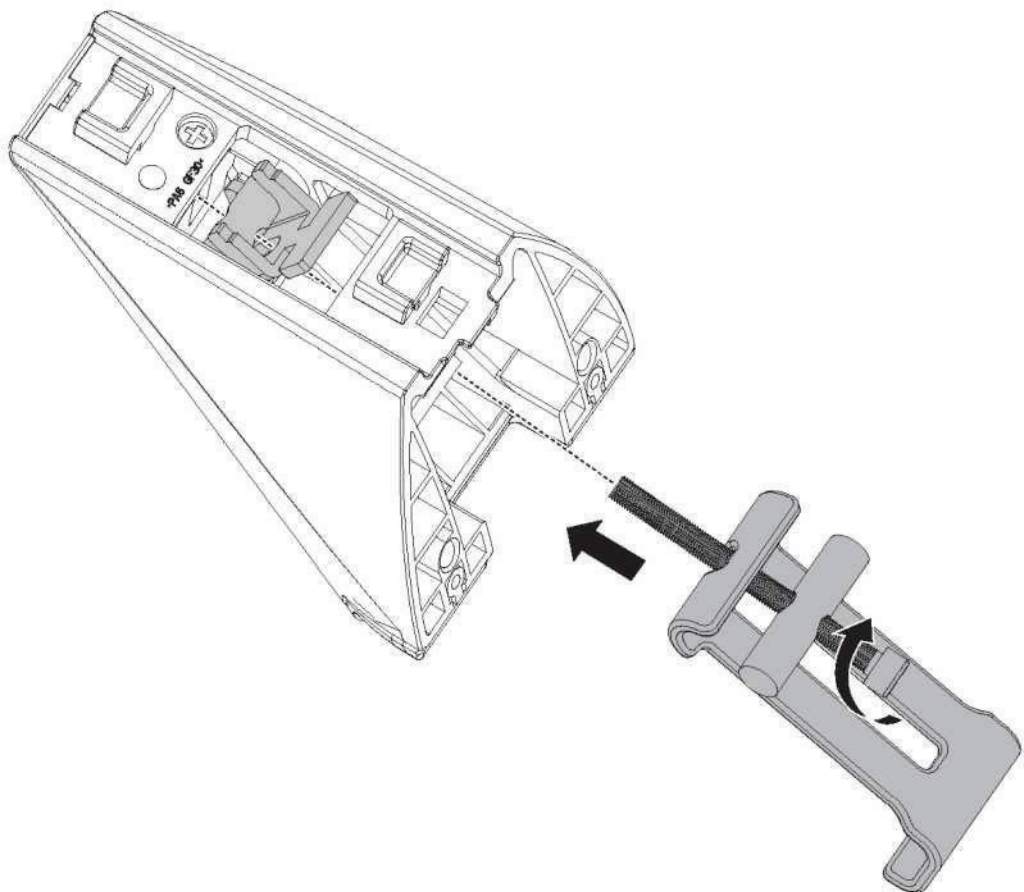

3

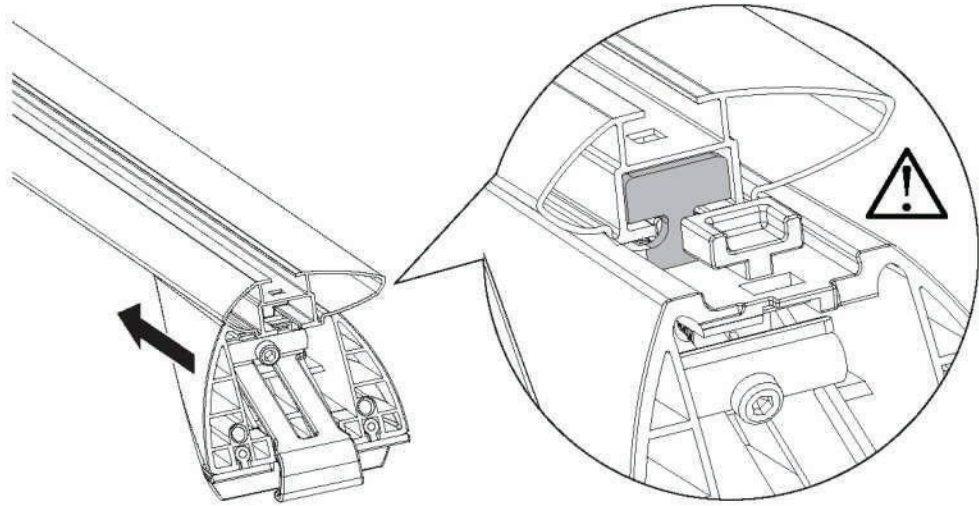
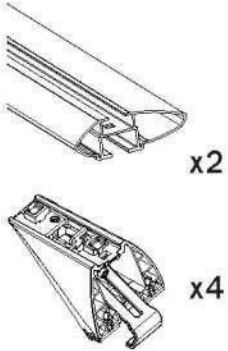

4



5

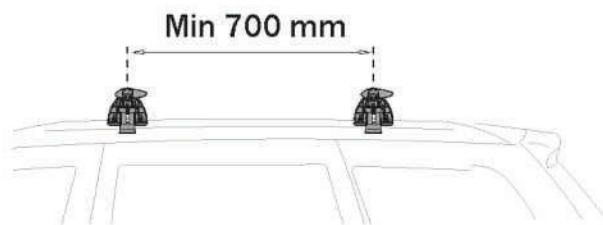
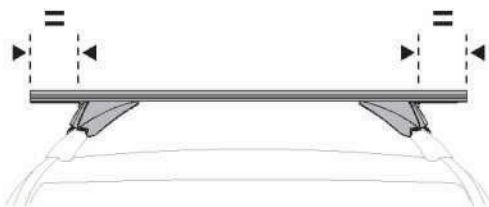
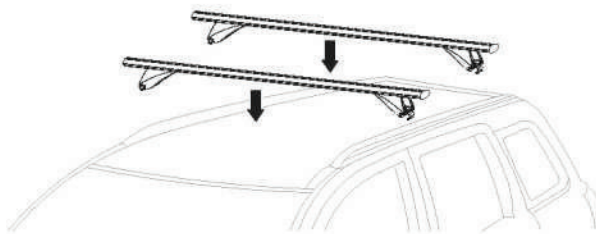

6

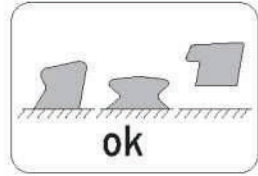
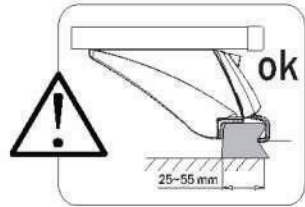
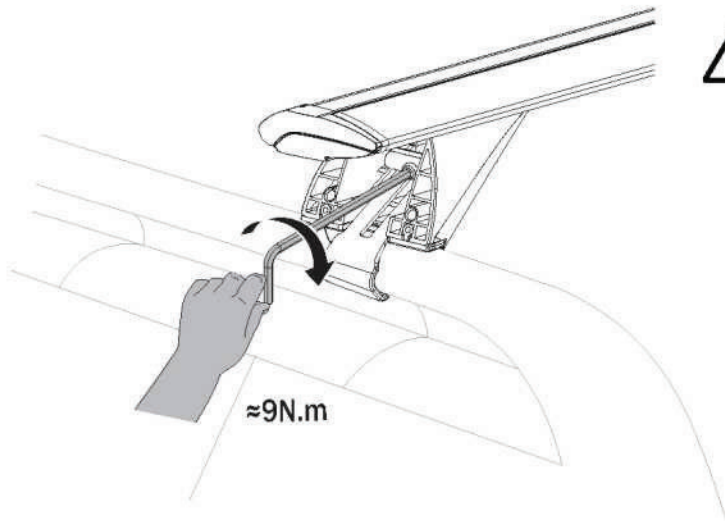

7

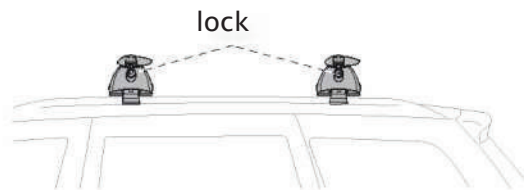
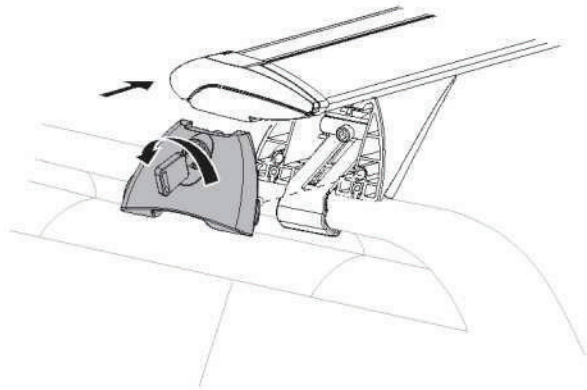
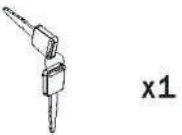
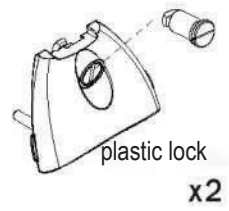
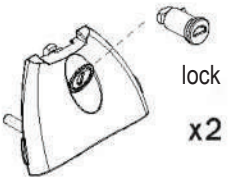

OPTIONAL  
ACCESSORIES

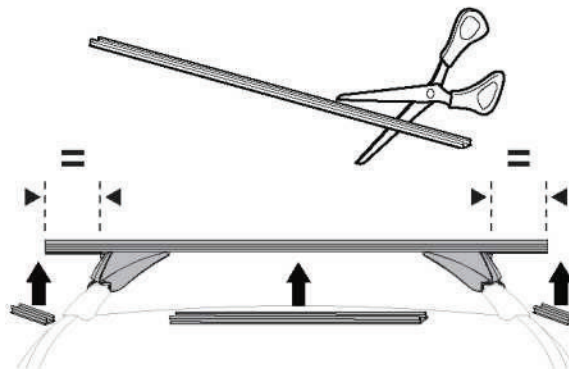

8

