

## HEED Pro 60cm suksiteline Käyttöohje

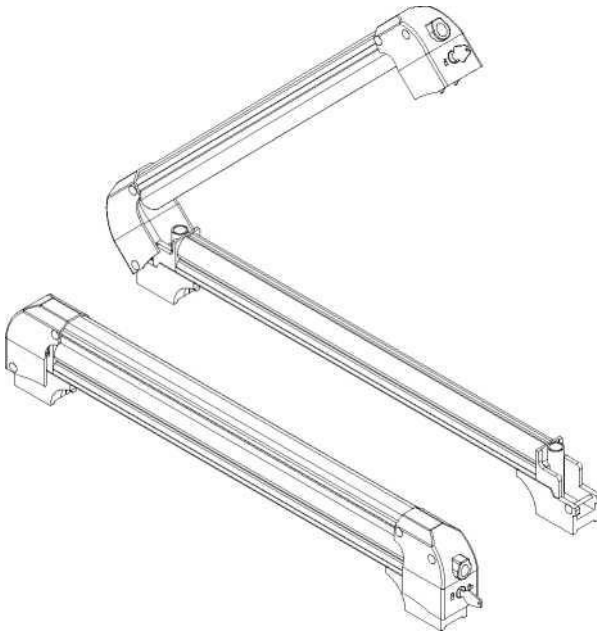

# VAROITUKSET

## TELINEEN ASENNUS

Puutteellisesti kiinnitetty kuorma ja väärin asennetut kattotelineet ja tarviketelineet voivat irrota matkan aikana ja aiheuttaa vakavan onnettomuuden. Siksi asennus, käsittely ja käyttö on suoritettava tuotteen ja ajoneuvon ohjeiden mukaisesti.

Tutustu näiden ohjeiden lisäksi kattotelineiden asennusohjeisiin ja ajoneuvon käyttöohjeisiin.

Nämä ohjeet on säilytettävä yhdessä ajoneuvon käyttöohjeiden kanssa, ja ne on pidettävä mukana ajoneuvossa käytön aikana ja matkalla.

Oman turvallisuutesi vuoksi käytä vain sellaisia kattotelineitä, jotka on hyväksytty käytettäväksi ajoneuvossasi.

Jos kattotelineissä ei ole määritelty etu- ja takatelineen välistä etäisyyttä, etäisyyden on oltava vähintään 700 mm tai mahdollisimman suuri. Huomaa, että kattotelineisiin ei saa tehdä muutoksia (esim. porata reikiä).

Tarkista kiinnikkeiden ja kuorman kireys:

- Ennen matkan alkua.
- Kun olet ajanut lyhyen matkan telineiden tai kuorman kiinnittämisen jälkeen.
- Säännöllisin väliajoin pidemmillä matkoilla.
- Useita kertoja jos ajat maastossa.
- Sen jälkeen, kun matka on keskeytetty ja ajoneuvo on jätetty valvomatta (tarkista ulkopuolisten tekemien vaurioiden varalta).

## TELINEEN KUORMAAMINEN

Älä ylitä kattotelineille tai tarviketelineelle määriteltyä enimmäiskuormaa tai ajoneuvon valmistajan suosittelemaa enimmäiskuormaa.

Maksimi kattokuorma - kattotelineiden + lisätelineiden + kuorman paino.

Kuorman on jakauduttava tasaisesti siten, että painopiste on mahdollisimman matalalla.

Kuorma ei saa ulottua merkittävästi kattotelineiden kuormauspinnan ulkopuolelle.

## AJAMINEN JA SÄÄDÖKSET

Ajonopeuden on vastattava kuljetettavaa kuormaa ja virallisia nopeusrajoituksia. Jos nopeusrajoituksia ei ole, suosittelemme 120 km/h enimmäisnopeutta.

Kuljetettaessa mitä tahansa kuormaa ajoneuvon nopeudessa on otettava huomioon kaikki olosuhteet, kuten tien kunto, tien pinta, liikenneolosuhteet, tuuli jne. Ajoneuvon käsiteltävyys, kaarreajo-ominaisuudet, jarrutusmatka ja herkkyys sivutuulelle muuttuvat, kun kuormaa lisätään katolle.

Maastoajoa ei suositella, ja se voi vahingoittaa ajoneuvoa tai varusteita.

## HUOLTO

Suksiteline on puhdistettava ja huollettava huolellisesti erityisesti talvikuukausina. Käytä vain vettä ja tavallista autoshampoota ilman alkoholia, valkaisuaineita tai ammoniakkia.

Polttoainetalouden ja muiden tienkäyttäjien turvallisuuden vuoksi suksiteline ja kattotelineet on poistettava, kun niitä ei käytetä.

Tarkista suksiteline säännöllisesti vaurioiden varalta. Vaihda kadonneet, vaurioituneet tai kuluneet osat. Käytä vain alkuperäisiä varaosia, jotka on hankittu asiantuntijalta, jälleenmyyjältä tai valmistajalta.

Kattotelineisiin ja suksitelineeseen tehdyt muutokset sekä muiden kuin valmistajan toimittamien varaosien tai lisävarusteiden käyttö johtavat valmistajan takuun raukeamiseen ja vastuun raukeamiseen aineellisista vahingoista tai onnettomuuksista. Noudata näitä ohjeita tarkasti ja käytä vain mukana toimitettuja alkuperäisiä osia.

## PAINORAJAT



Kattotelineet



Suksiteline 4 / lumilautateline 2:  
2,75 kg  
Suksiteline 6 / lumilautateline 4:  
3,5 kg



Kuorma enintään 35 kg



Enintään 75 kg  
ellei toisin  
mainita



= 3.9kg

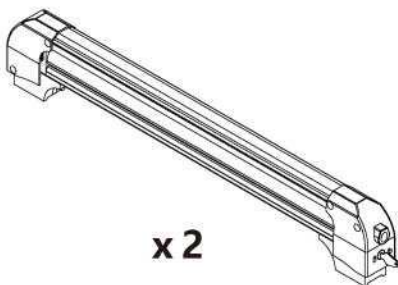
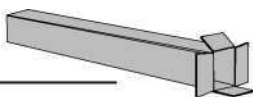

x 2

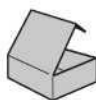

x 4

M6X20 18X24



x 4

M6



x 1



x 1

1

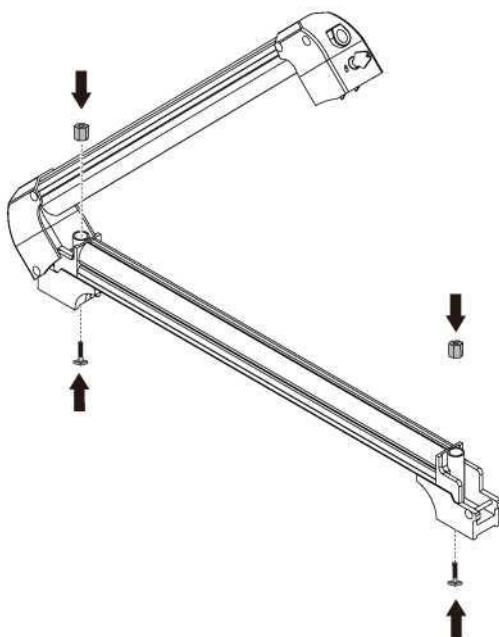
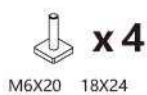

2

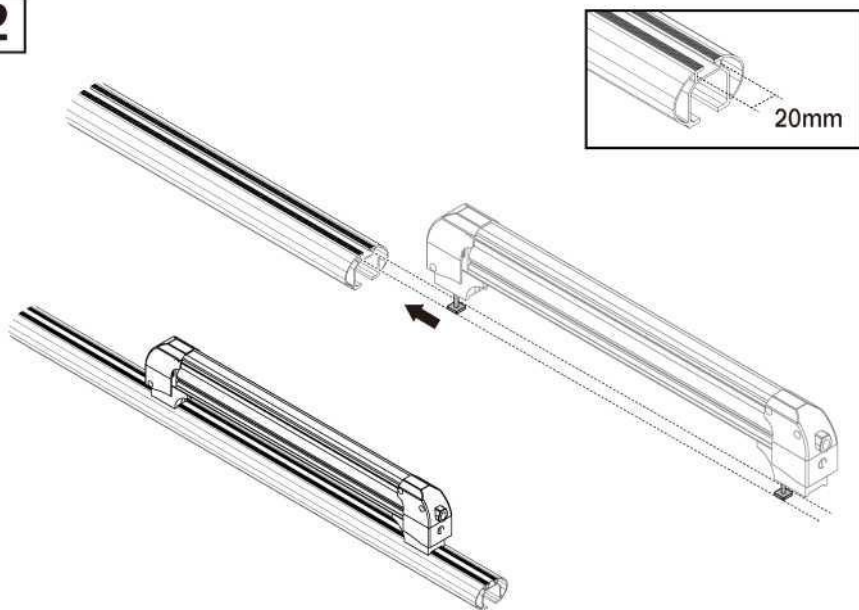

3

x 1

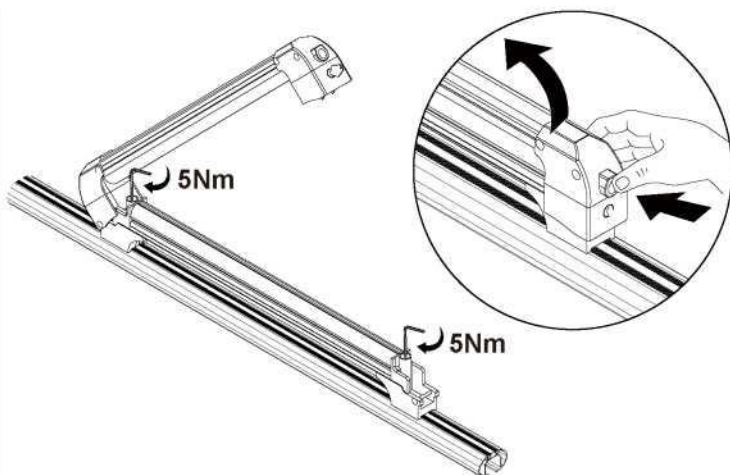

4

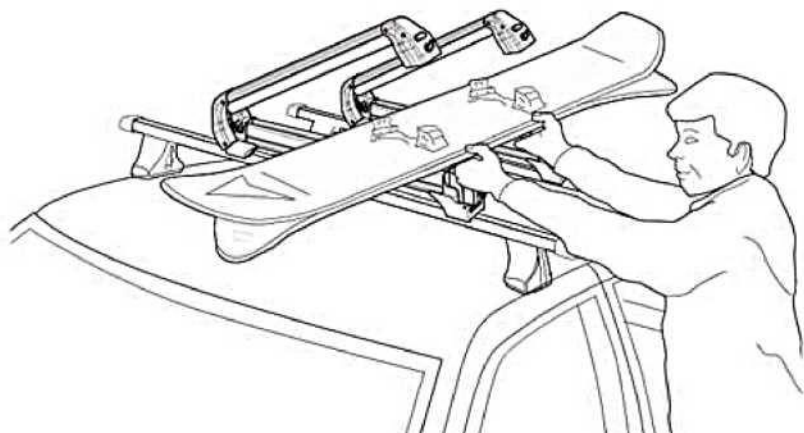
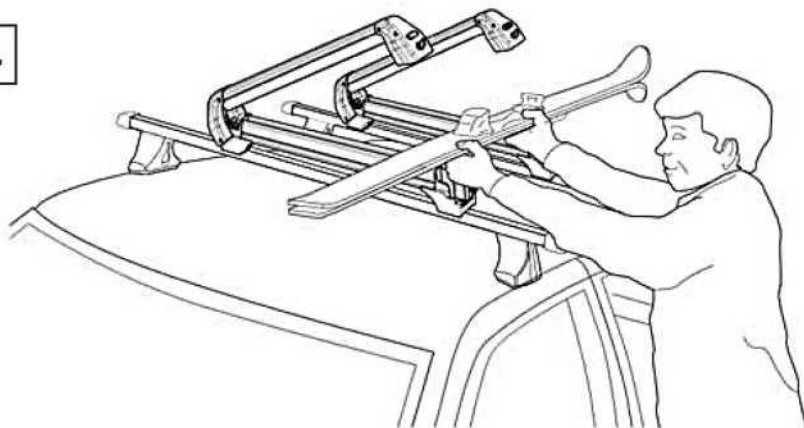

5

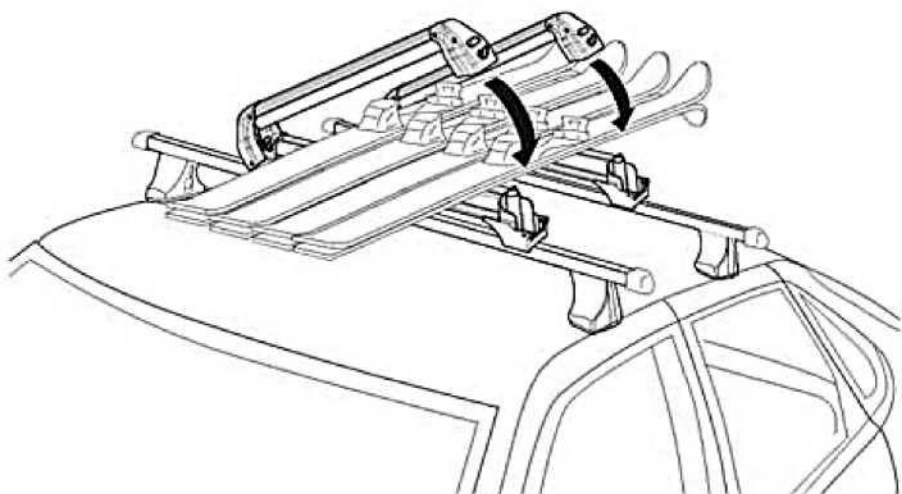

6



x 1

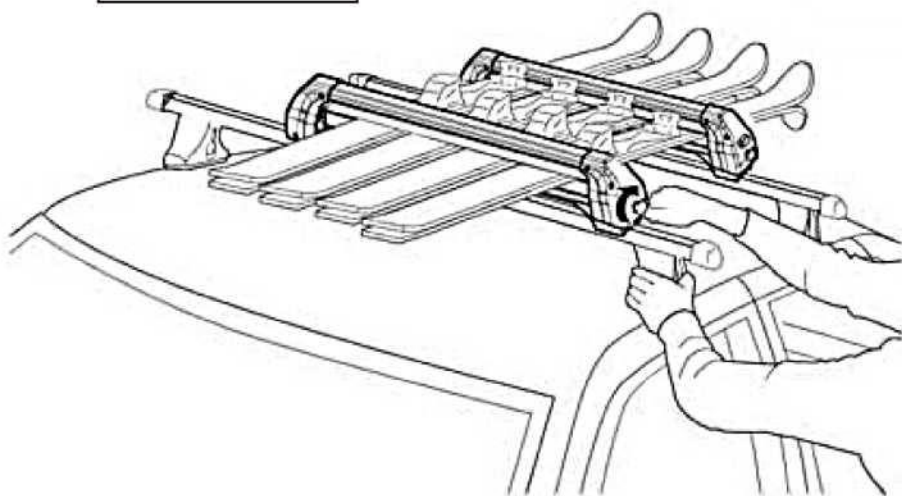

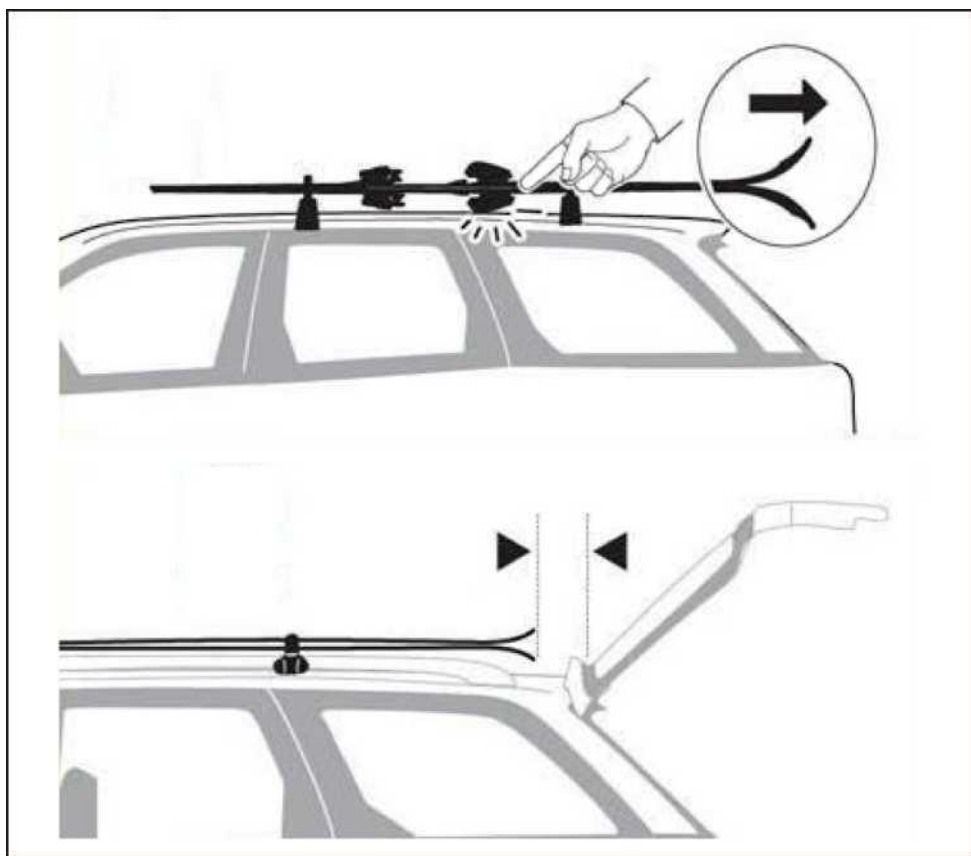
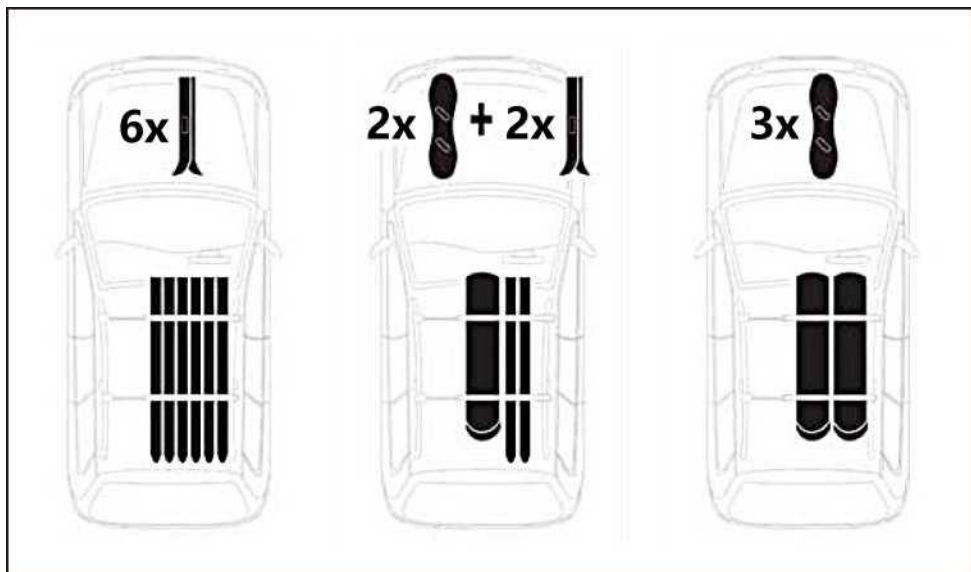

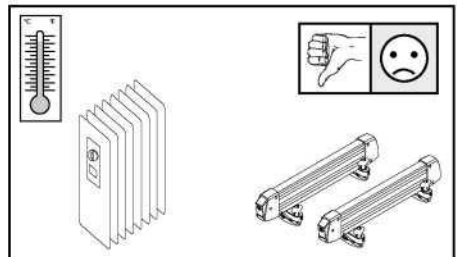
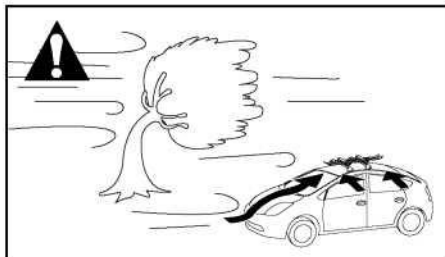
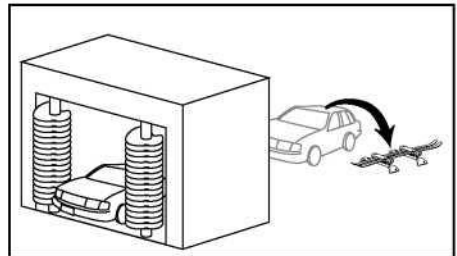
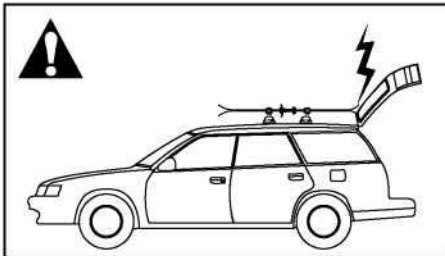
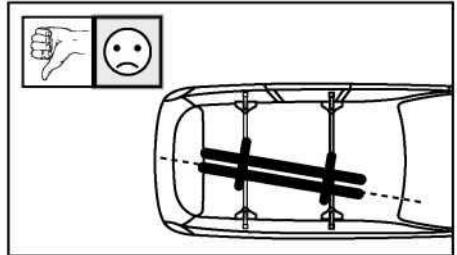
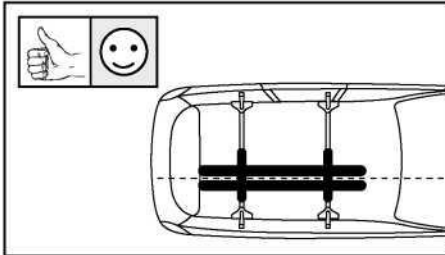
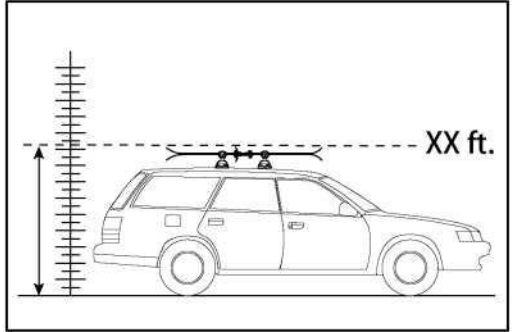
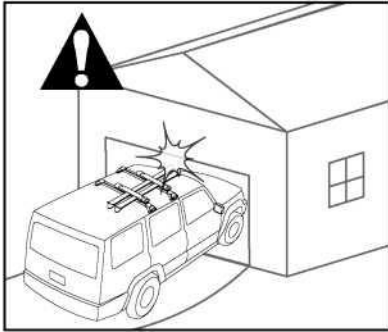

**SUOMITRADING**

Suomi Trading Oy  
Areenakatu 7, 37570 Lempäälä  
[asiakaspalvelu@suomitrading.fi](mailto:asiakaspalvelu@suomitrading.fi)

A1



## HEED Pro 60cm skidhållare

## Anvisningar

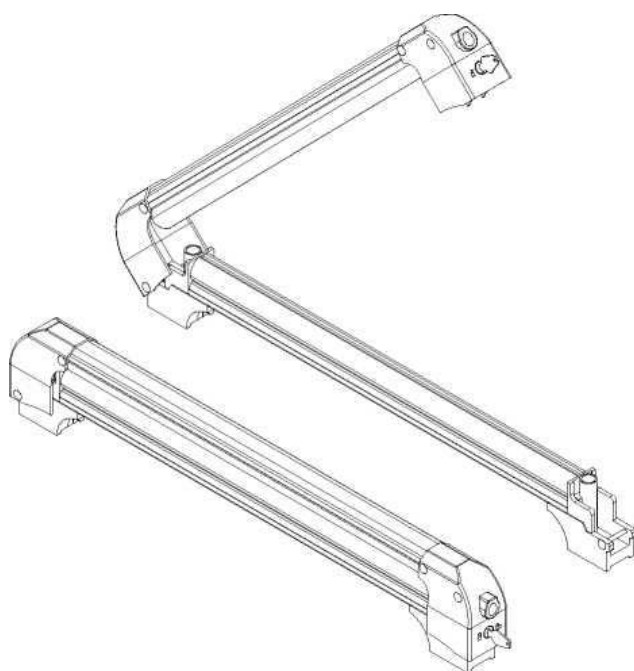

# VARNINGAR

## INSTALLATION AV SKIDHÅLLAREN

Dåligt säkrad last och felaktigt installerade taksräcken och tillbehörshållare kan lossna under färd och orsaka en allvarlig olycka.

Därför måste installation, hantering och användning ske i enlighet med produkt- och fordonsinstruktionerna.

Utöver dessa anvisningar bör du läsa installationsanvisningarna för taksräcken och bilens bruksanvisning.

Dessa anvisningar ska förvaras tillsammans med bilens bruksanvisning och medföras i bilen under användning och vid resor.

För din egen säkerhet bör du endast använda taksräcken som är godkända för användning i ditt fordon.

Om taksräcken inte anger avståndet mellan främre och bakre taksräcken ska avståndet vara minst 700 mm eller så stort som möjligt.

Observera att inga ändringar (Lex. borring av hål) får göras på taksräcken.

Kontrollera fästelementens spänning och lasten:

- Innan du börjar din resa.
- När du har kört en kort sträcka efter att ha monterat taksräcken eller lasten.
- Med jämna mellanrum på längre resor.
- Oftare i terräng.
- Efter att en resa har avbrutits och fordonet har lämnats obevakat (kontrollera om det finns skador som gjorts av andra personer).

## LASTNING AV HÅLLAREN

Överskrid inte den maximala belastning som anges för taksräcket eller tillbehörshållaren eller den maximala belastning som rekommenderas av fordonstillverkaren.

Maximal taklast = taksräckenas vikt + ytterligare ställningar + last.

Lasten måste vara jämnt fördelad så att tyngdpunkten ligger så lågt som möjligt.

Lasten får inte sträcka sig betydligt längre än taksräckenas lastyta.

## KÖRNING OCH BESTÄMMELSER

Körhastigheten ska motsvara den last som transporteras och de officiella hastighetsgränserna. Om det inte finns några hastighetsbegränsningar rekommenderar vi en högsta hastighet på 120 km/h.

Vid transport av en last måste fordonets hastighet ta hänsyn till alla förhållanden, såsom vägförhållanden, vägbeläggning, trafikförhållanden, vind osv. Fordonets hantering, kurvtagningsegenskaper, bromssträcka och känslighet för sidovindar förändras när last läggs på taket.

Terrängkörning rekommenderas inte och kan skada fordonet eller utrustningen.

## UNDERHÅLL

Skidhållaren måste rengöras och underhållas noggrant, särskilt under vintermånaderna. Använd endast vatten och vanligt bilschampo utan alkohol, blekmedel eller ammoniak.

För att minska bränsleförbrukningen och skydda andra trafikanter måste skidhållaren och taksräcken tas bort när de inte används.

Kontrollera regelbundet om skidhållaren är skadad. Byt ut borttappade, skadade eller slitna delar. Använd endast originalreservdelar som köpts från en specialist, återförsäljare eller tillverkaren.

Ändring av taksräcken och skidhållare och användning av andra reservdelar eller tillbehör än de som tillhandahålls av tillverkaren medför att tillverkarens garanti upphör att gälla och att dess ansvar för materiella skador eller olyckor upphör att gälla. Följ dessa anvisningar noggrant och använd endast de medföljande originaldelarna.

## VIKTBEGRÄNSNINGAR



Taksräcken



Skidhållare 4 / snowboardhållare 2:  
2,75 kg  
Skidhållare 6 / snowboardhållare 4:  
3,5 kg



Belastning upp till 35 kg



Upp till 75 kg om  
inget annat  
anges



= 3.9kg

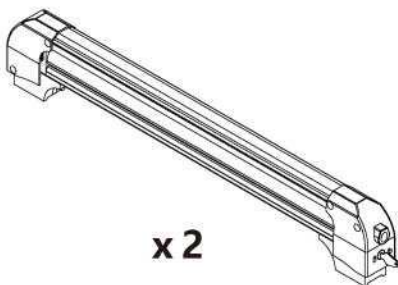
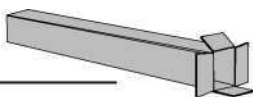

x 2

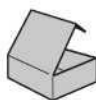

x 4

M6X20 18X24



x 4

M6



x 1



x 1

1

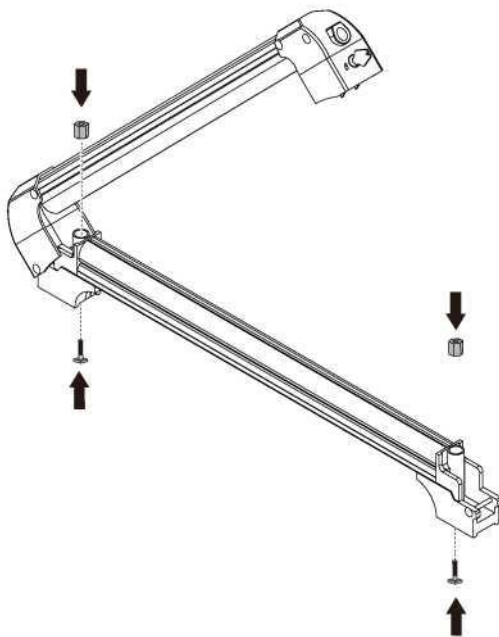
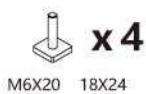

2

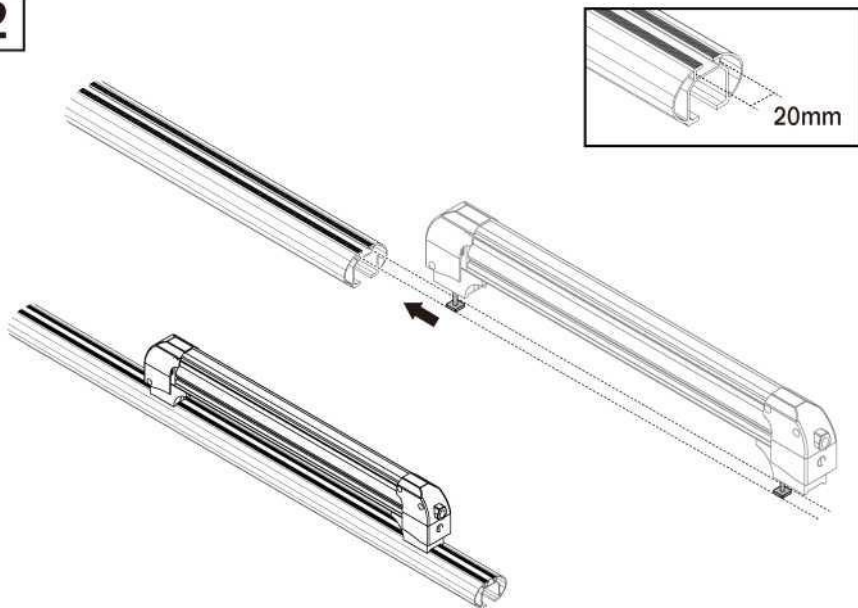

3

x 1

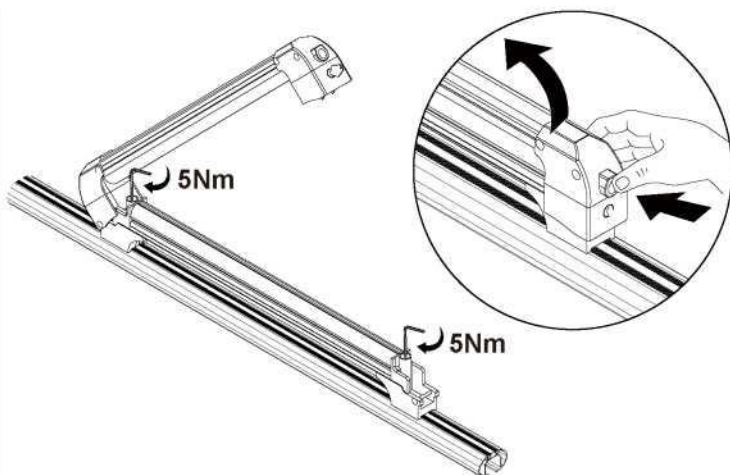

4

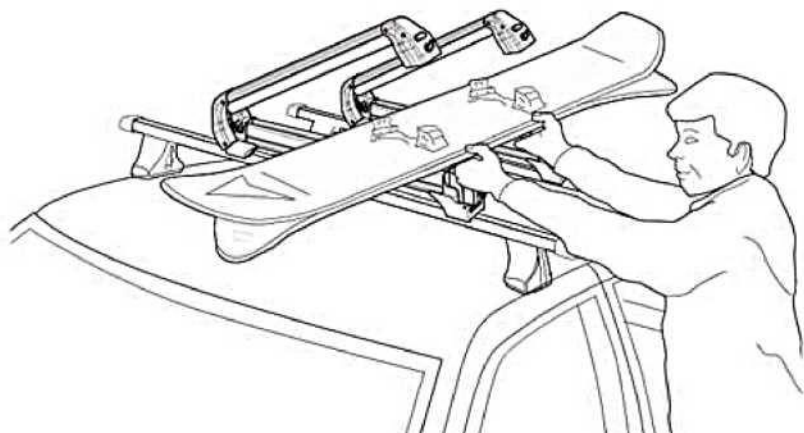
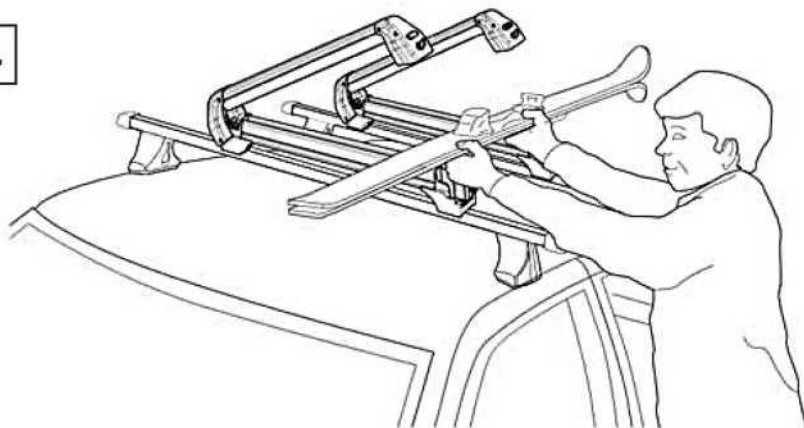

5

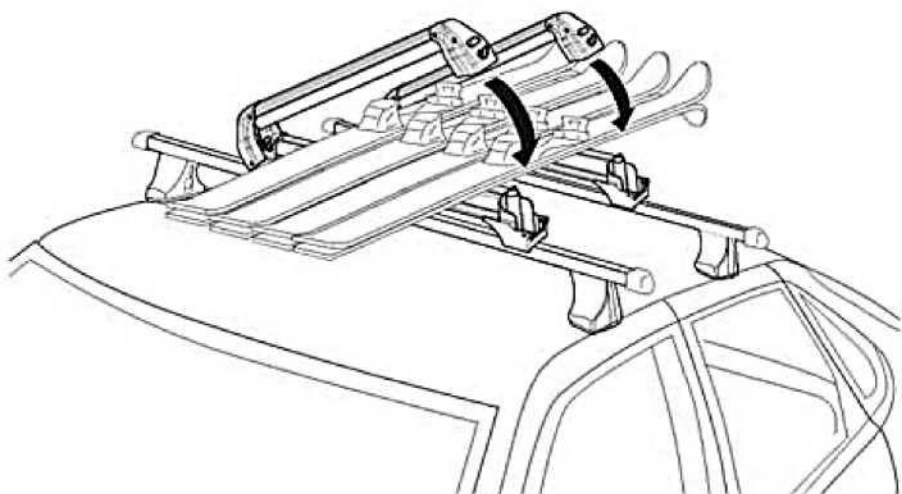

6

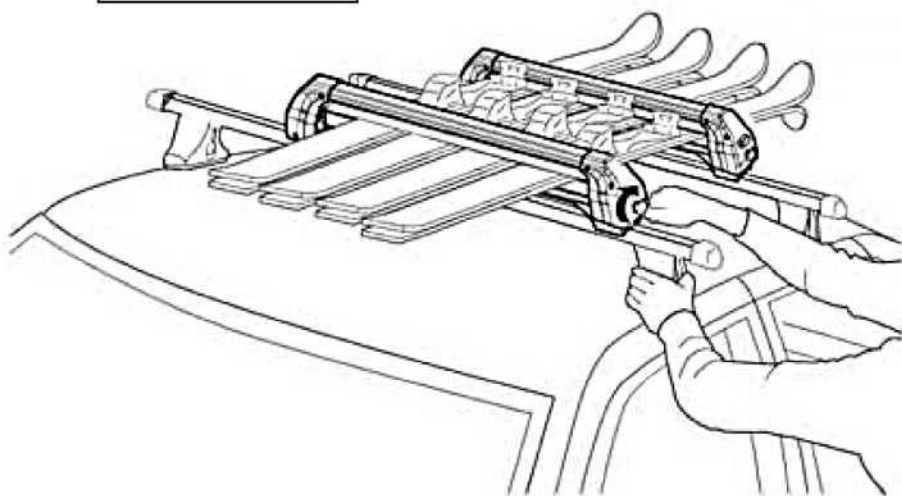
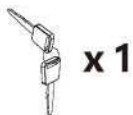

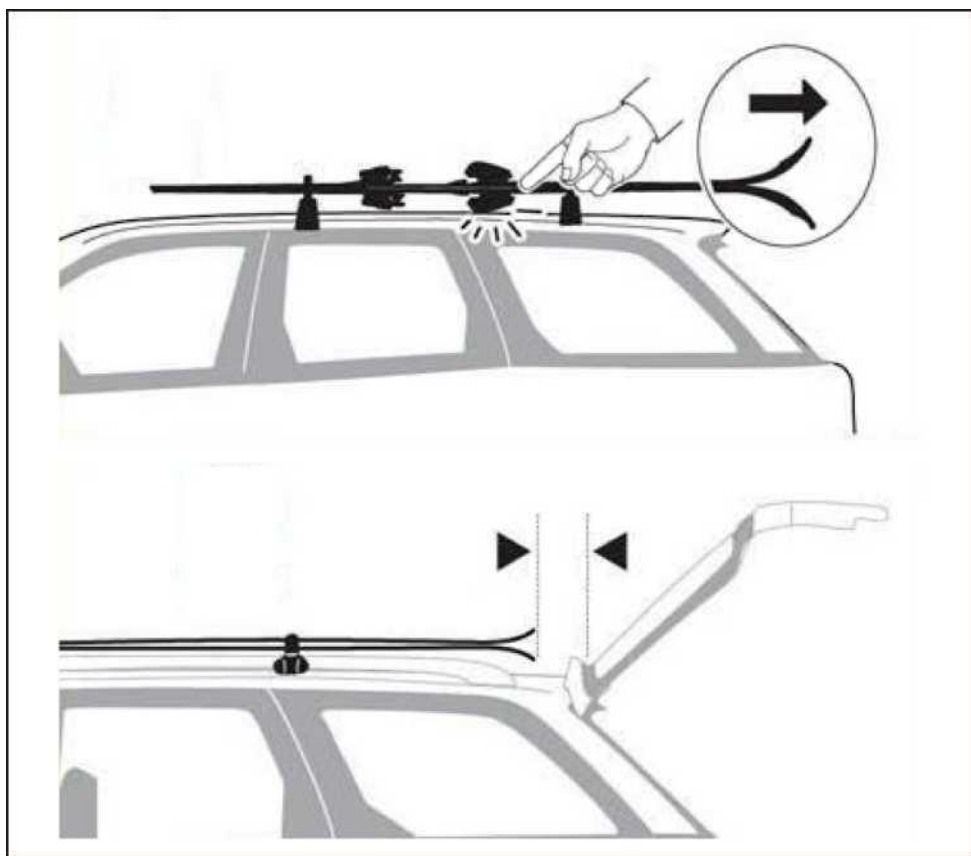
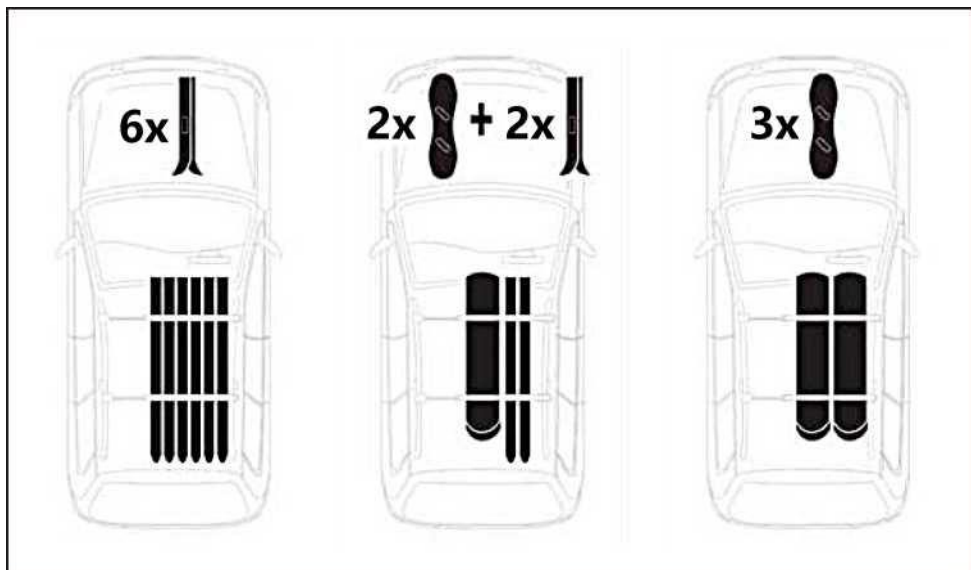

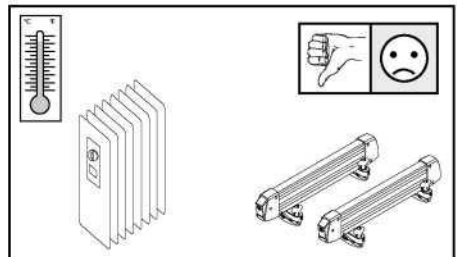
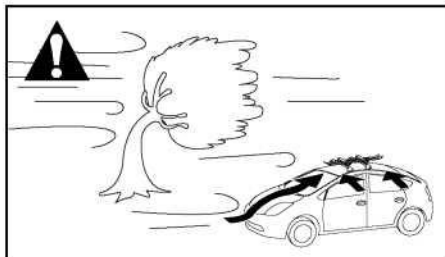
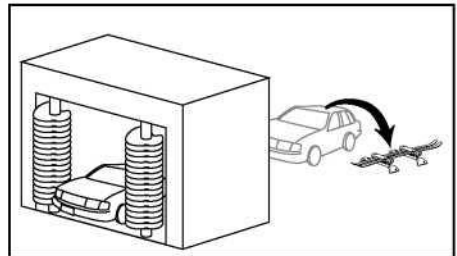
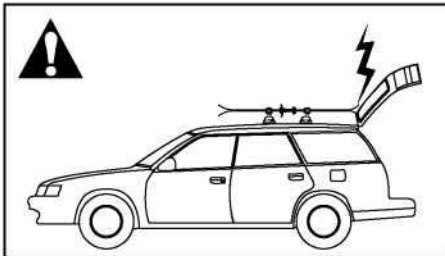
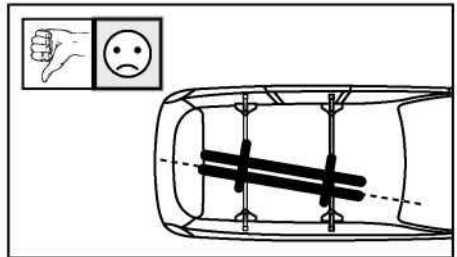
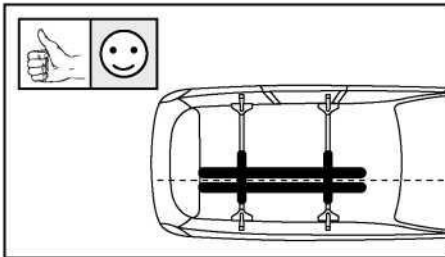
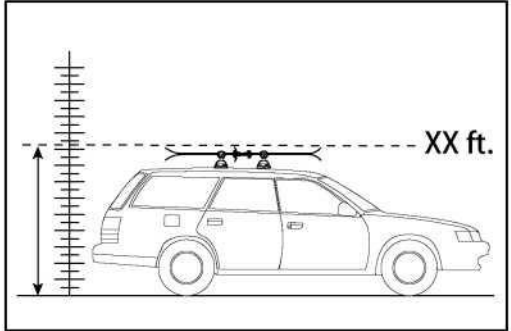
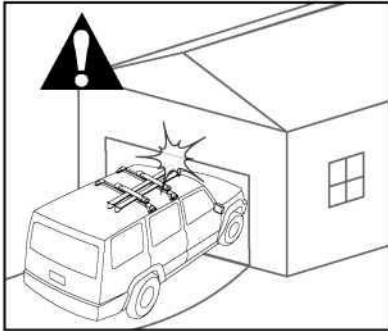

**SUOMITRADING**

Suomi Trading Oy  
Areenakatu 7, 37570 Lempäälä  
[asiakaspalvelu@suomitrading.fi](mailto:asiakaspalvelu@suomitrading.fi)



**HEED Pro 60cm SNOWBOARD RACK**

**Instructions**

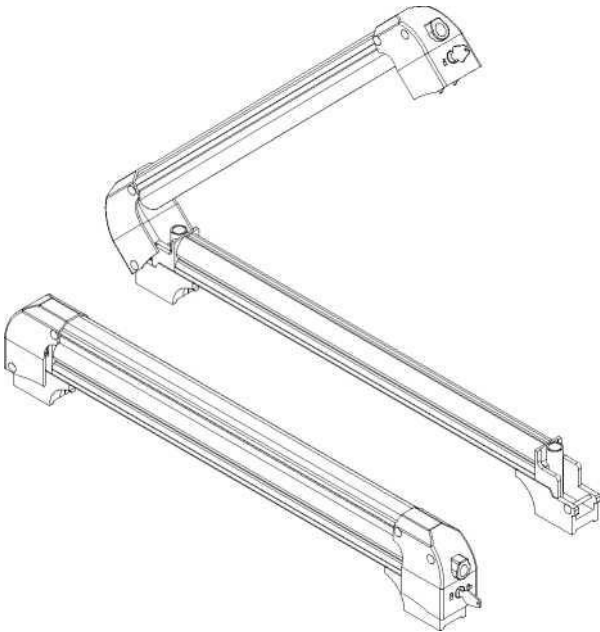

# WARNINGS

## RACK INSTALLATION

Inadequately secured loads and incorrectly mounted roof racks and accessory racks can come loose during travel and cause serious accidents! Therefore, installation, handling and use must be carried out in accordance with product and vehicle instructions.

In addition to these instructions, review the mounting instructions for the roof rack and the operating instructions of the vehicle. These instructions should be kept together with the vehicle's operating instructions and carried in the vehicle when in use and en route.

For your own safety, you should only use roof racks that are authorized for use with your vehicle.

For roof racks that do not specify the distance between the front and rear crossbars, the distance shall be at least 700 mm or as large as possible. Please note that changes (e.g. additional drill holes) to the accessory rack's attachment system are not permissible.

Check attachment hardware and load for tight fit and function:

- Before the start of any journey.
- After driving a short distance following rack or load install.
- At regular intervals on longer journeys.
- More frequently on rough terrain.
- After interruption of a journey during which the vehicle was left unsupervised (check for damage due to outside intervention).

## RACKLOADING

Do not exceed the maximum load specified for the roof rack, accessory rack or the maximum load recommended by the vehicle manufacturer.

Max Roof Load - weight of roof rack + weight of accessory racks + weight of load.

Load shall be uniformly distributed with the lowest possible center of gravity.

Load should not substantially extend beyond the loading surface of the roof rack.

## VEHICLE DRIVING AND REGULATIONS

The speed driven must be suited to the load transported and to official speed limits. In the absence of any speed limits, we recommend a maximum speed of 75 mph (120 km/h).

When transporting any load, the speed of the vehicle must take into account all conditions such as the state of the road, the surface of the road, traffic conditions, wind, etc. Vehicle handling, cornering, braking and sensitivity to side winds will change with the addition of roof top loads.

Off-road driving is not recommended and could result in damage to your vehicle or your gear.

## MAINTENANCE

The accessory rack should be carefully cleaned and maintained, particularly during the winter months. Use only a solution water and standard car wash liquid without any alcohol, bleach or ammonium additives.

For reasons of fuel economy and the safety of other road users, the accessory rack and roof rack should be removed when not in use.

Periodically inspect accessory rack for damage. Replace lost, damaged or worn parts. Use only original spare parts obtained from a stocking specialist, dealer or manufacturer.

Any changes made to the roof racks and accessory racks as well as the use of spare parts or accessories other than those supplied by the manufacturer will lead to the lapsing of the manufacturer's warranty and liability for any material damage or accidents. You should observe these instructions to the letter and only use the original parts supplied.

## WEIGHT LIMITS



Rack



Ski Carrier 4 / Snowboard Carrier 2:  
6.06 lbs/ 2.75 kg  
Ski Carrier 6 / Snowboard Carrier 4:  
7.7 lbs/3.5 kg



Load Charge 77.1  
lbs. (35 kg) Max.



Not more than  
165 lbs. (75 kg)  
unless otherwise  
noted.



= 3.9kg

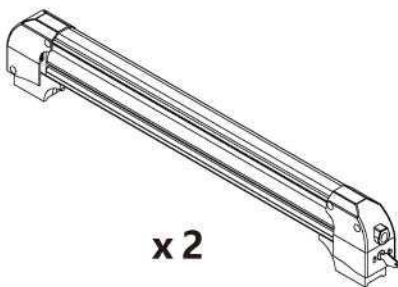
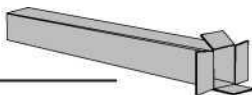

x 2



x 4

M6X20 18X24



x 4

M6



x 1



x 1

1

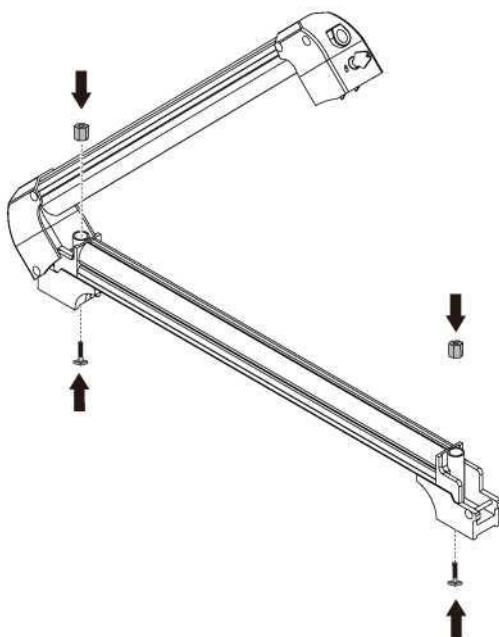
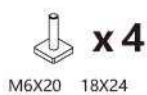

2

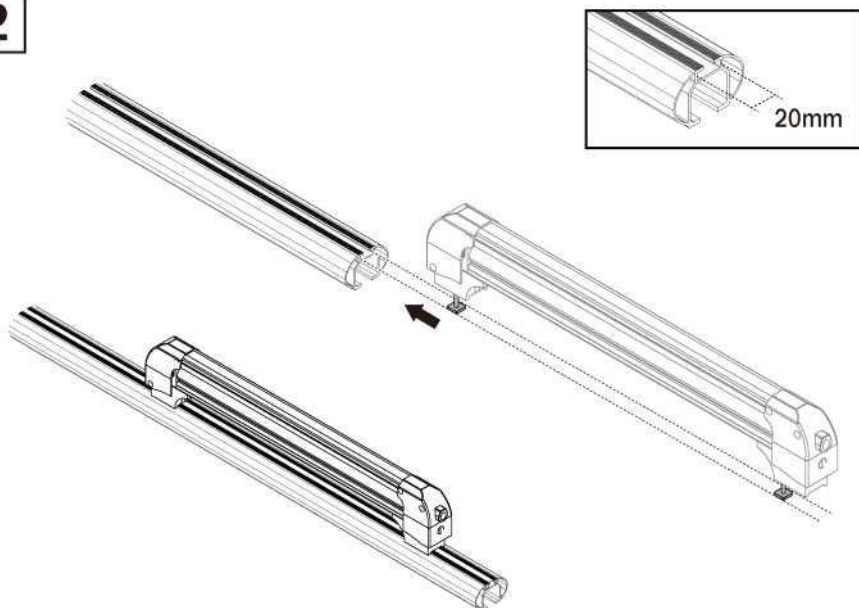

3

x 1

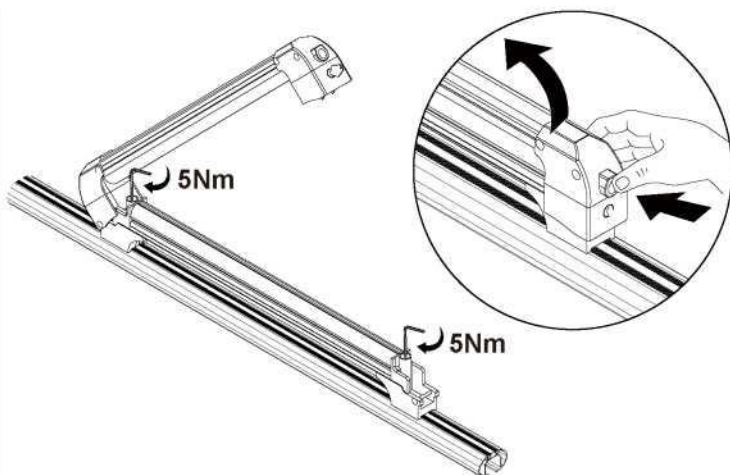

4

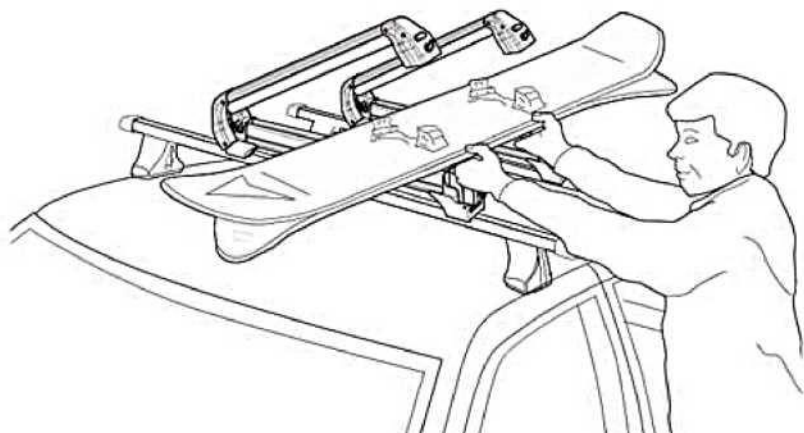
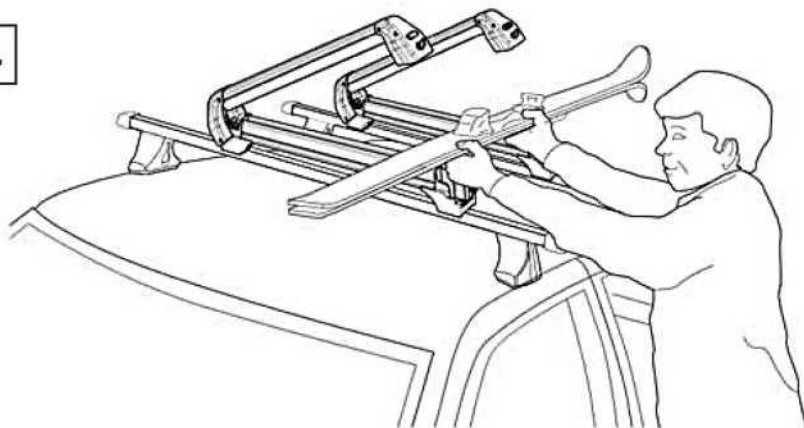

5

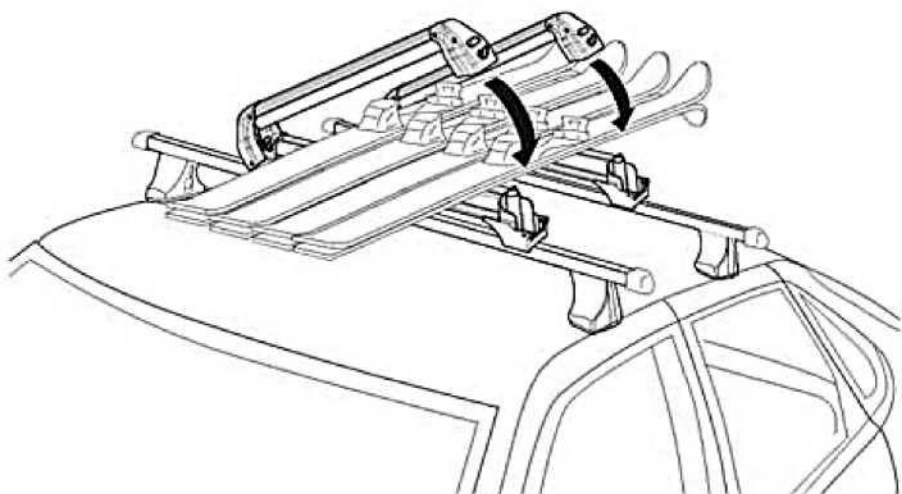

6

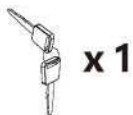

x 1

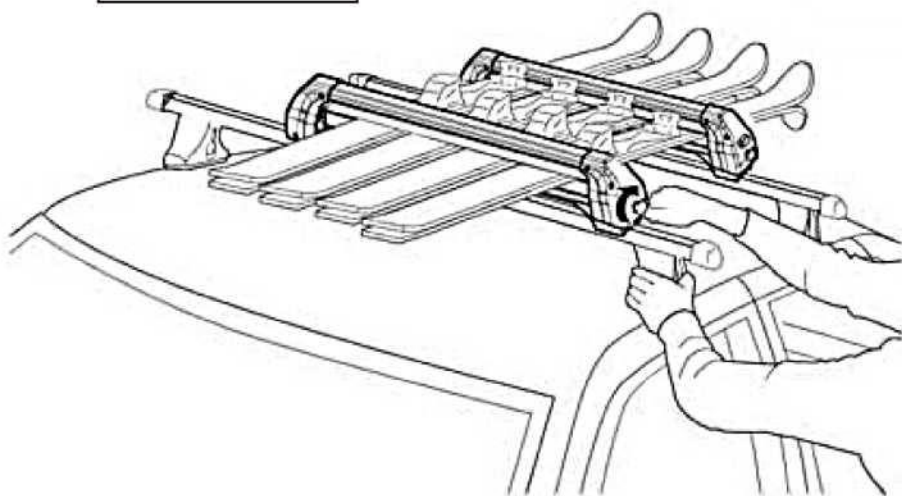

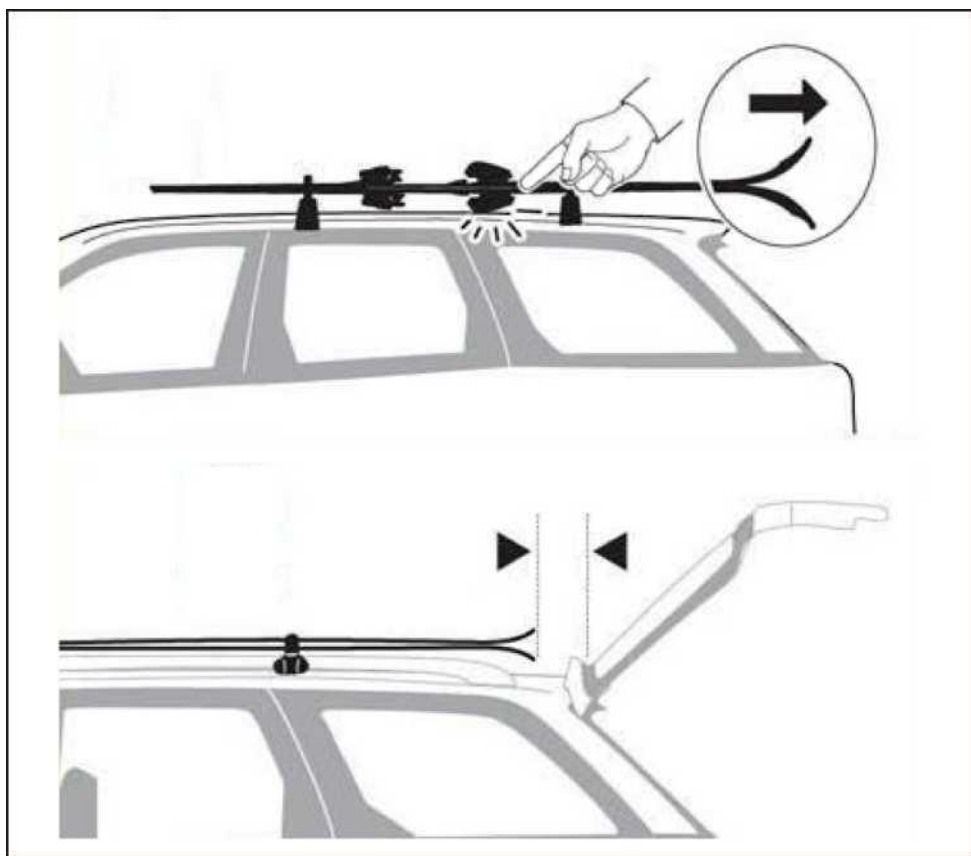
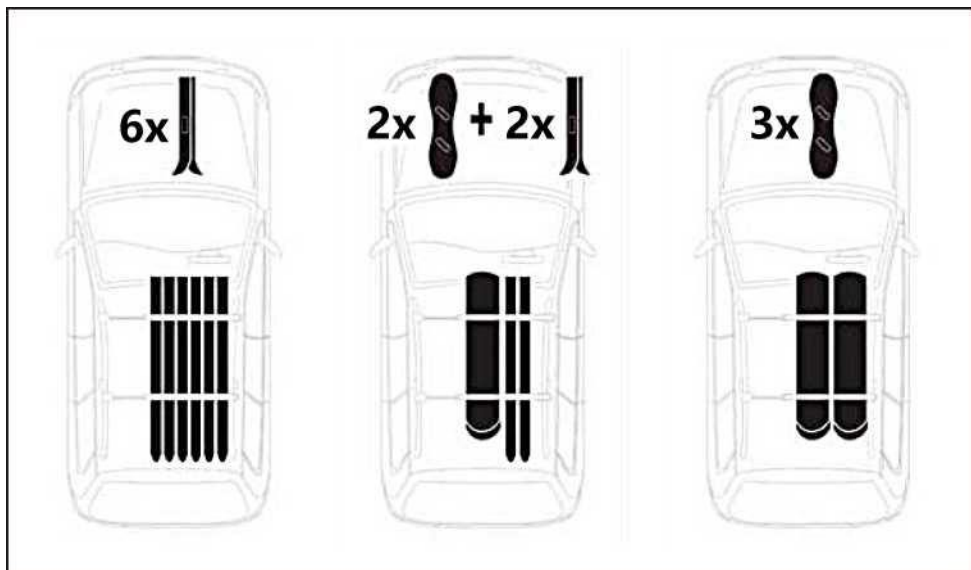

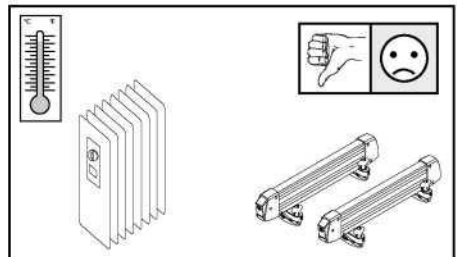
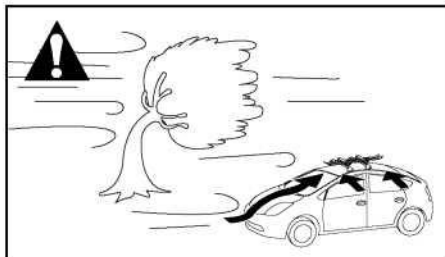
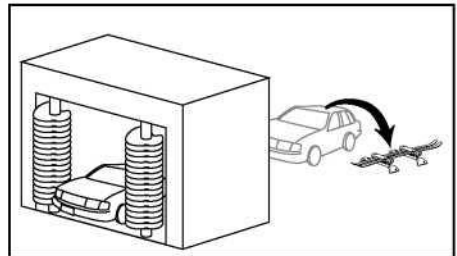
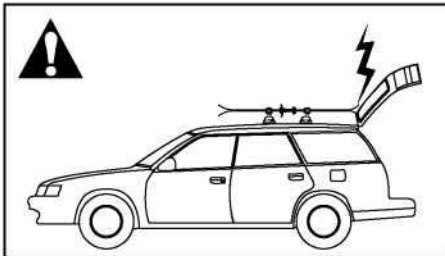
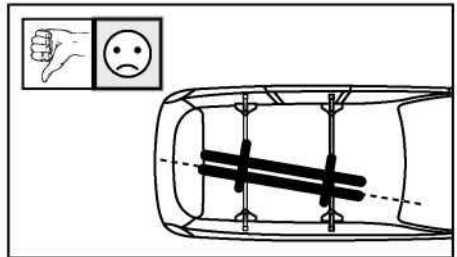
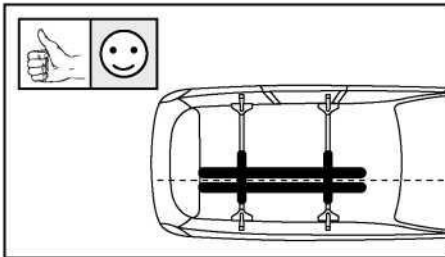
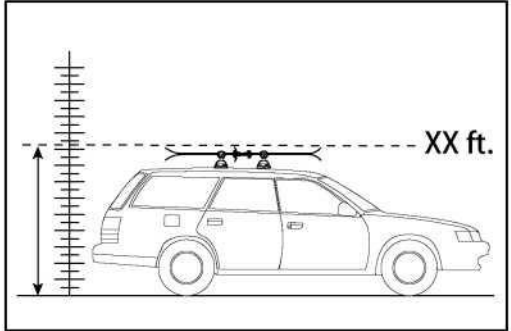
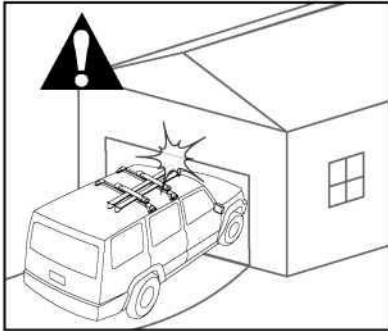

**SUOMITRADING**

Suomi Trading Oy  
Areenakatu 7, 37570 Lempäälä  
[asiakaspalvelu@suomitrading.fi](mailto:asiakaspalvelu@suomitrading.fi)