

# GXT classic sähköpöytä 1200x600mm

Asennusohje



< Alla olevat kuvat ovat vain viitteellisiä, katso todellinen tuote.>

Lue tämä käyttöohje huolellisesti ennen käyttöä. Säilytä ohje myöhempää tarvetta

# Käyttöohjeet

## Noudatettavat standardit

EN1730

EN527

BIFMA5

## Tekniset tiedot

Pylväät	2
Maksimikantavuus	50 kg
Maksiminopeus	15 mm/s
Alin korkeus	730 mm
Korkein korkeus	1 180 mm
Pöytälevyn koko	1 200 x 600 mm

## Tuoteluettelo

### Tarvikeluettelo

Huomio: Alla olevat piirustukset ovat vain ohjeellisia ja ne voivat poiketa hieman vastaanotetuista tuotteista ja varusteista. Ota yhteyttä asiakaspalveluun, jos jokin osa puuttuu tai sinulla on ongelmia asennuksen kanssa.

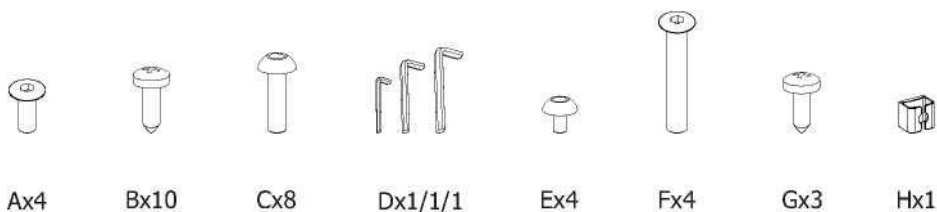

### Valmistelut ennen kokoamista

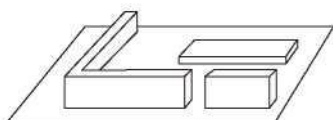



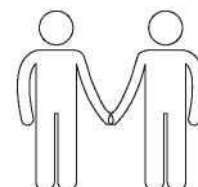











Suorita kokoonpano maton päällä naarmujen välttämiseksi. Ruuvinväännintä tarvitaan.

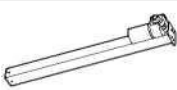

Kokoa pöytä kahden tai useamman henkilön voimin.

## Osaluettelo

Nro	Osa	Nro	Osa
①	Pöytälevy x1 	⑧	Suojus x1 
②	Tukilevy x2 	⑨	Säädin x1  + 
③	Palkki x1 	⑩	Verkkolaite x1 
④	Vasen pylväs x1 	⑪	Verkkolaitteen teline x1 
⑤	Oikea pylväs x1 	⑫	Virtapistoke x1 
⑥	Jalka x2 	⑬	Kytkimen johto x1 
⑦	Nostoakseli x1 	⑭	Koukku x1 

## Asennusohjeet

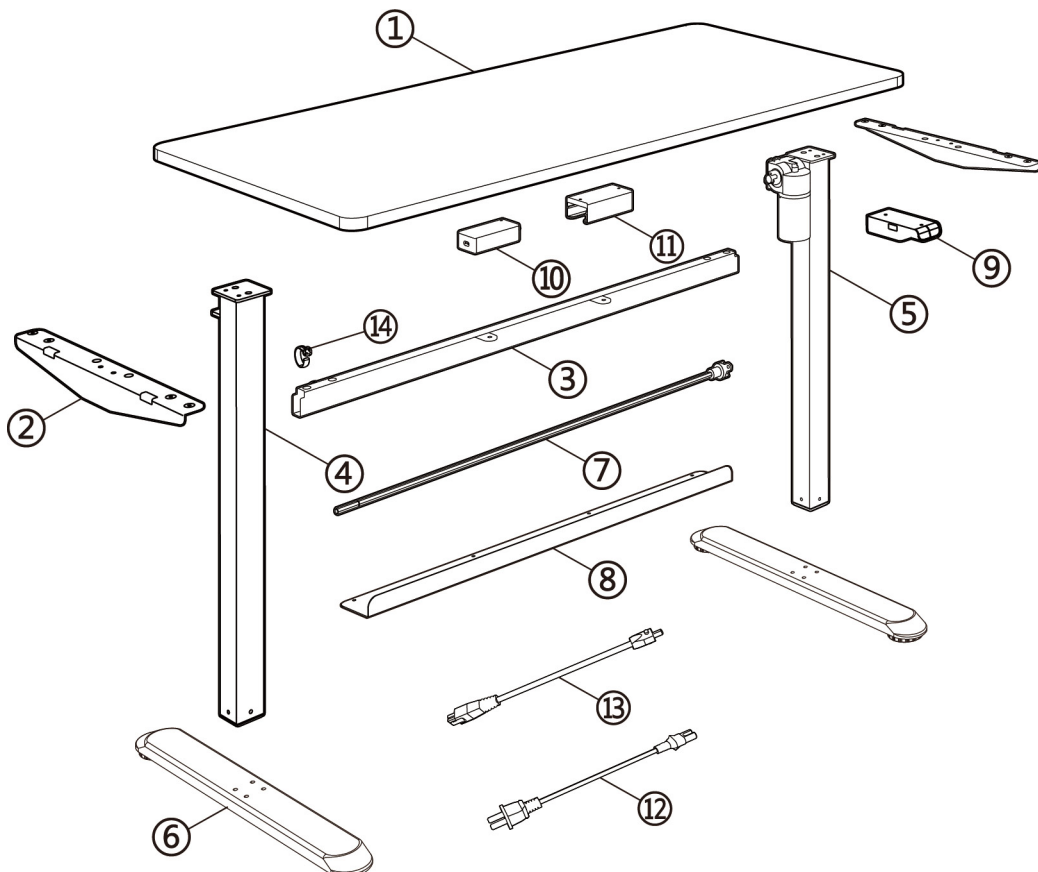

# Asennusvaiheet

**VAIHE 1**

Asenna jalat

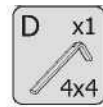
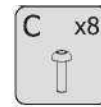
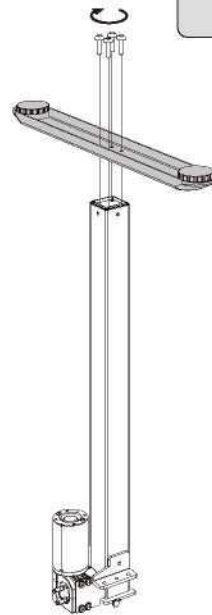
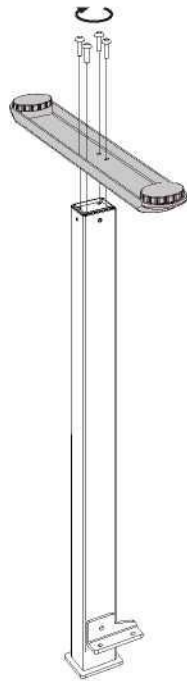

**VAIHE 2**

Liitä oikea pylväs palkkiin

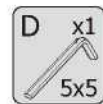
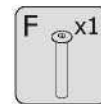
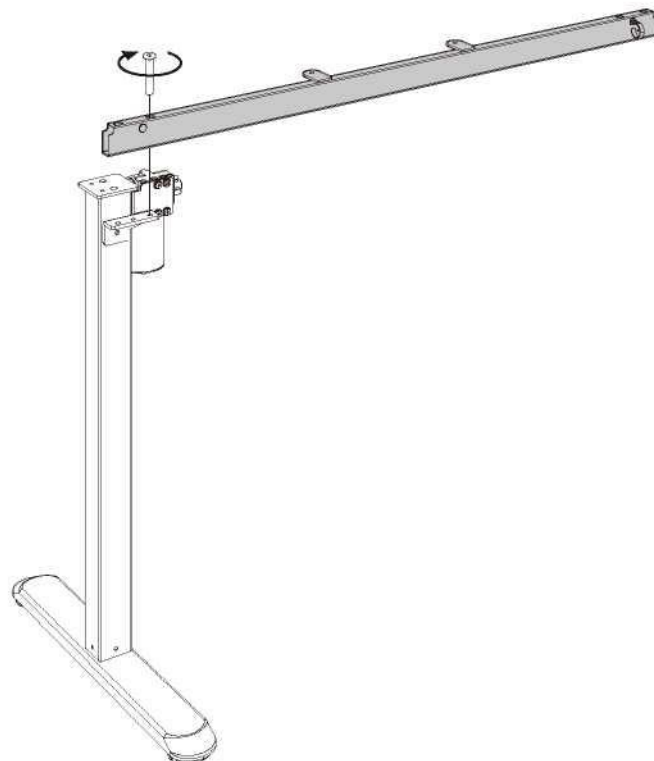

**VAIHE 3**

**Asenna nostoakseli**

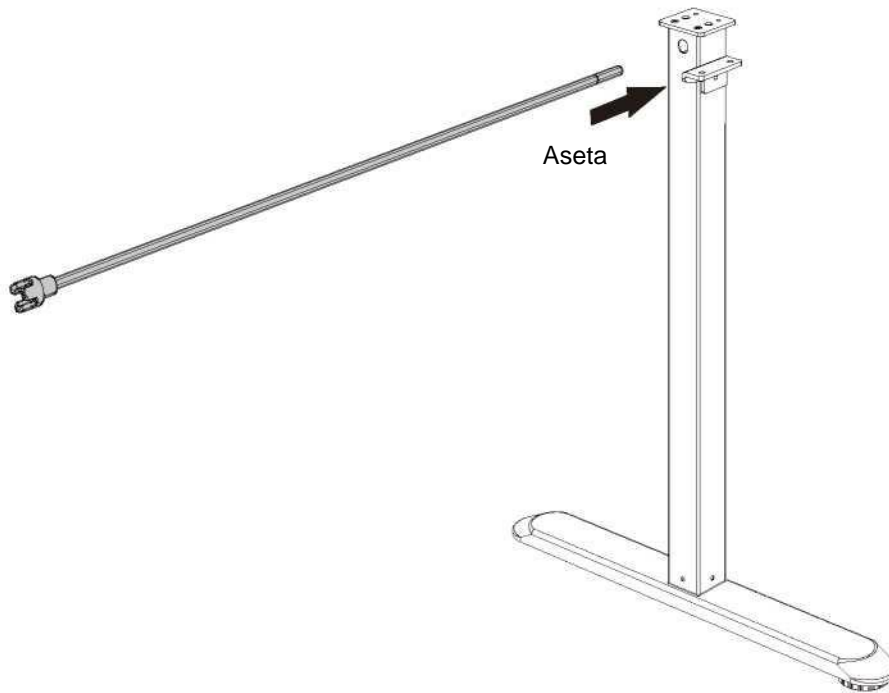

**!** Asennettaessa on kiinnitettävä huomiota siihen, että vasemman ja oikean pylvään korkeus pysyy samana.

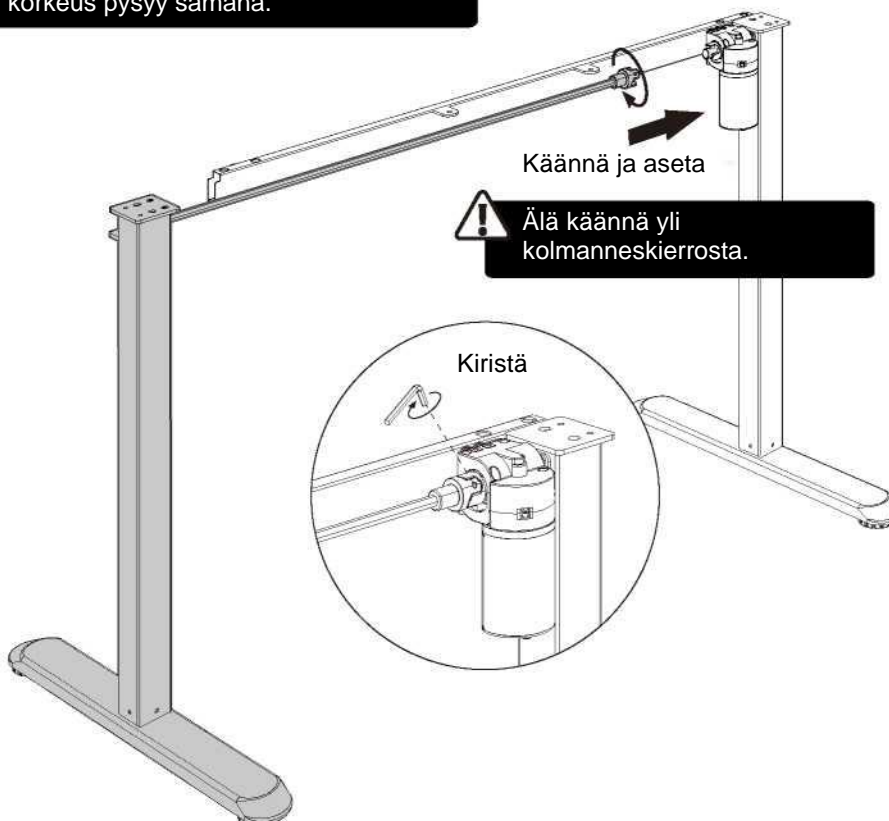
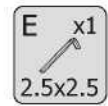

**VAIHE 4**

Liitä vasen pylväs palkkiin

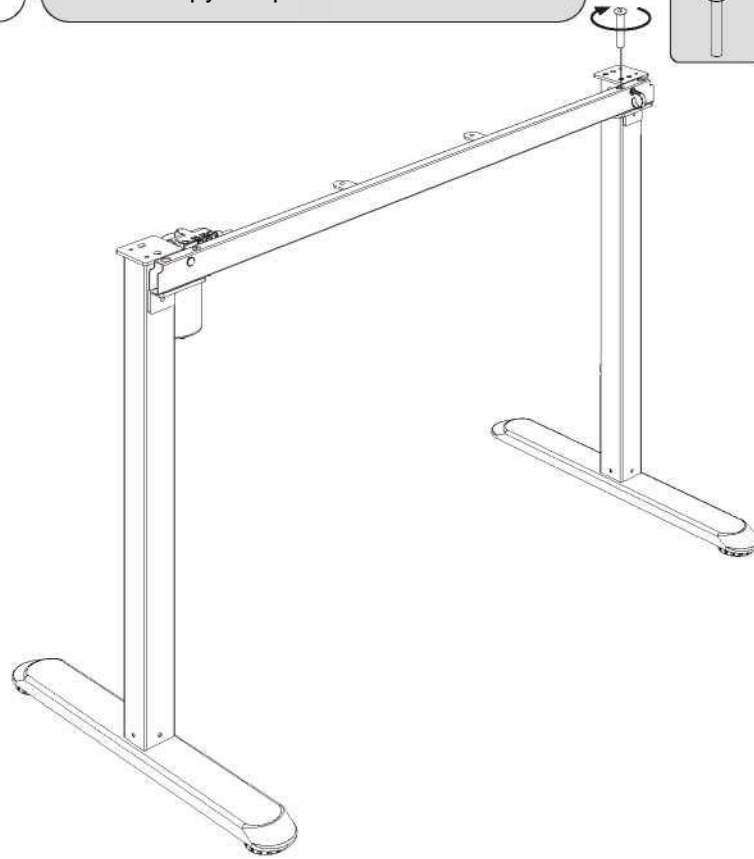
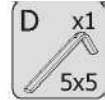
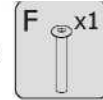
**VAIHE 5**

Asenna tukilevyt

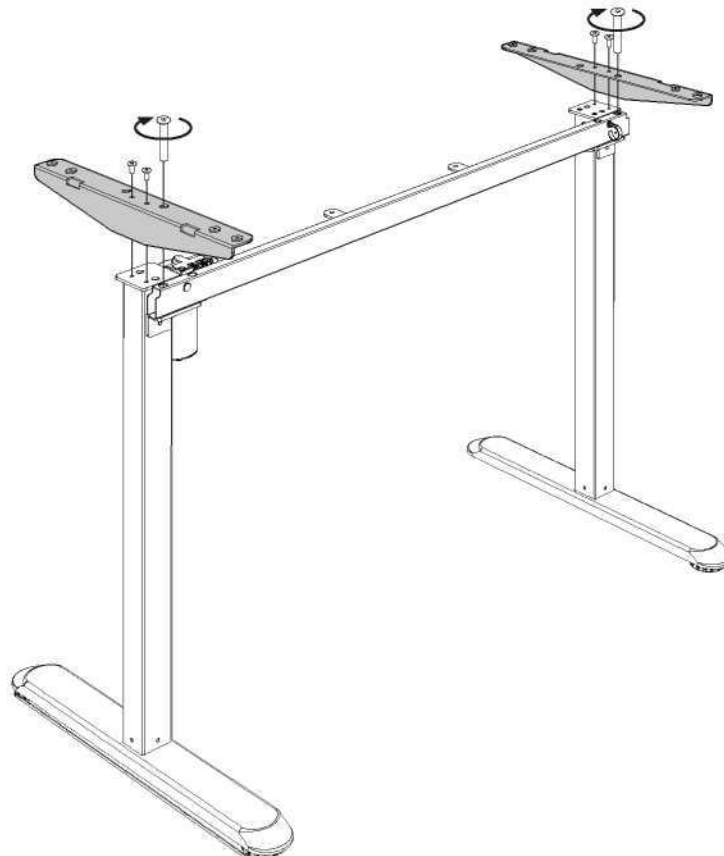
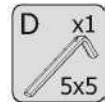
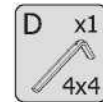
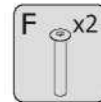
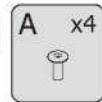

**VAIHE 6**

Asenna pöytälevy

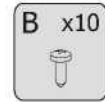

Ei sisälly

Ruuvien asennusjärjestys on 

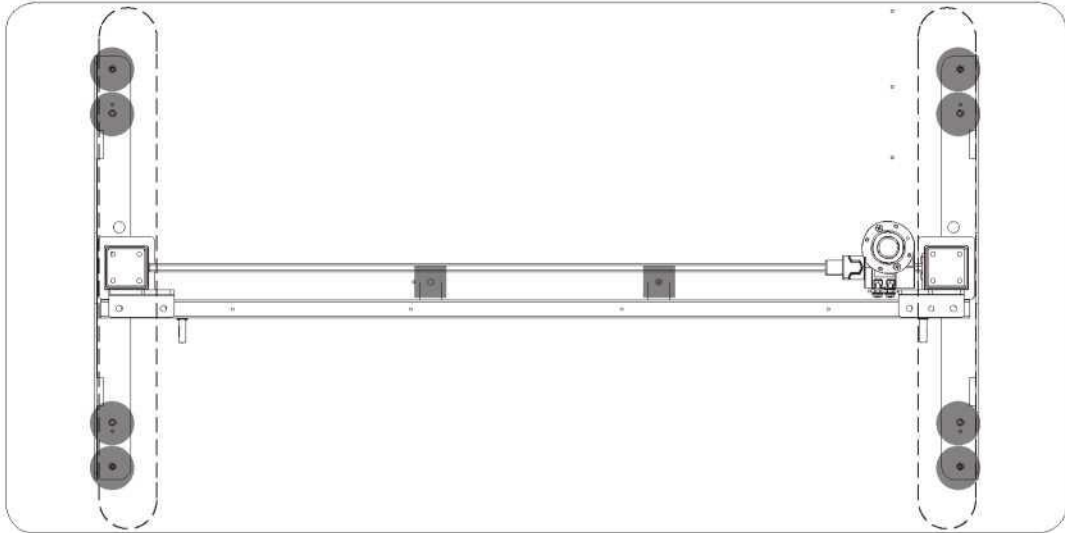

**VAIHE 7**

Asenna suojus

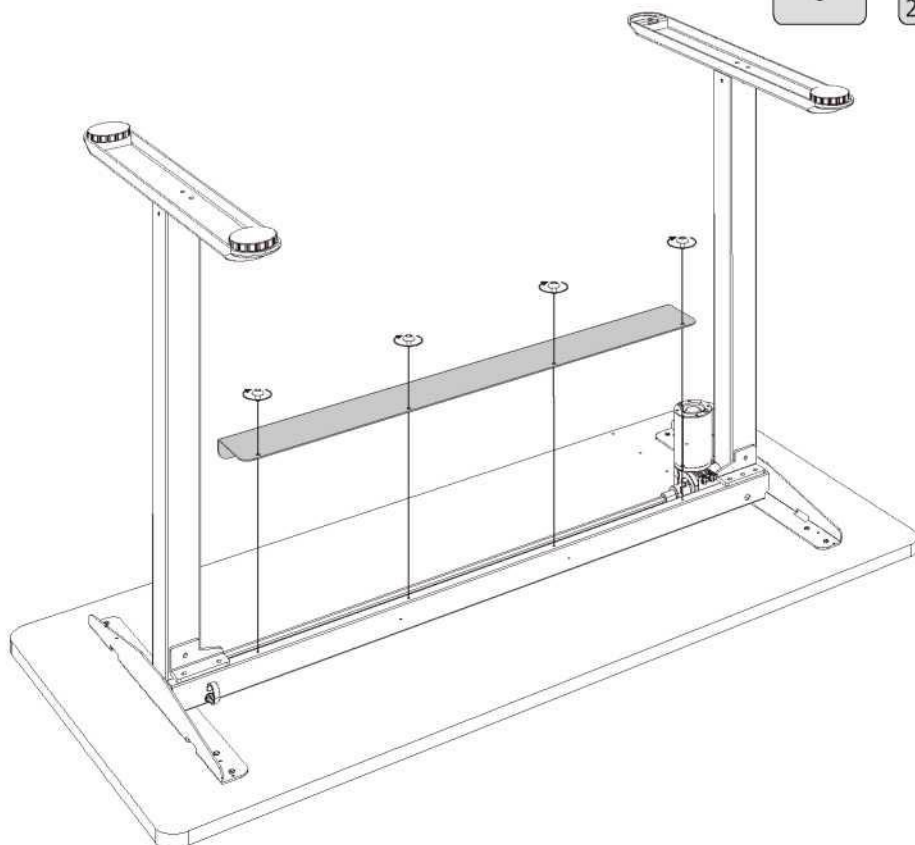
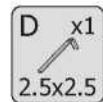

**VAIHE 8**

Asenna säädin



Ei sisälly

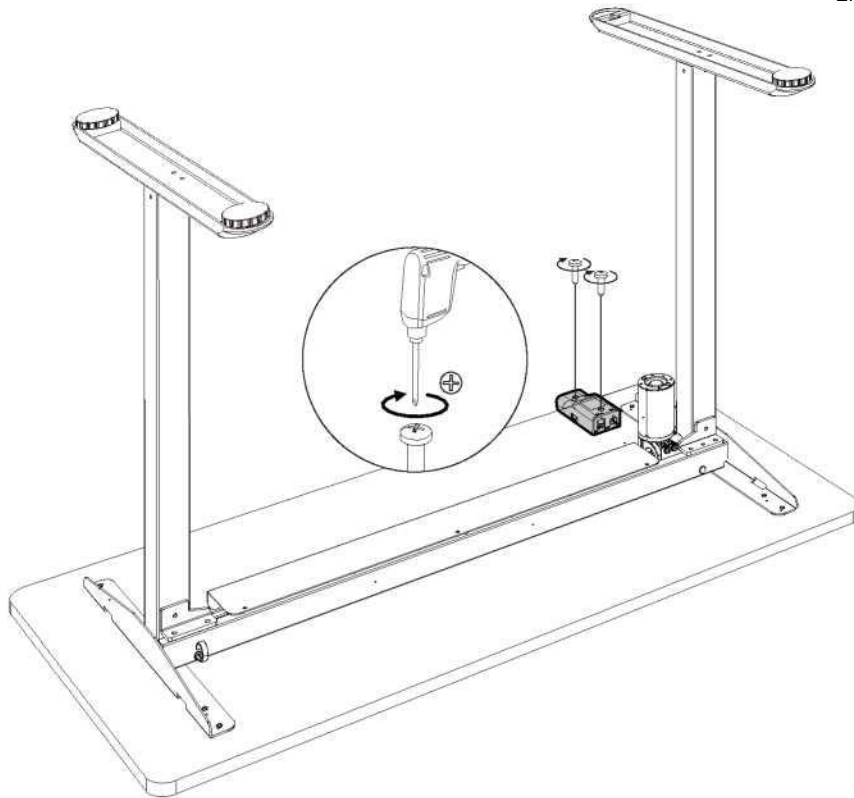

**VAIHE 9**

Asenna verkkolaite



Ei sisälly

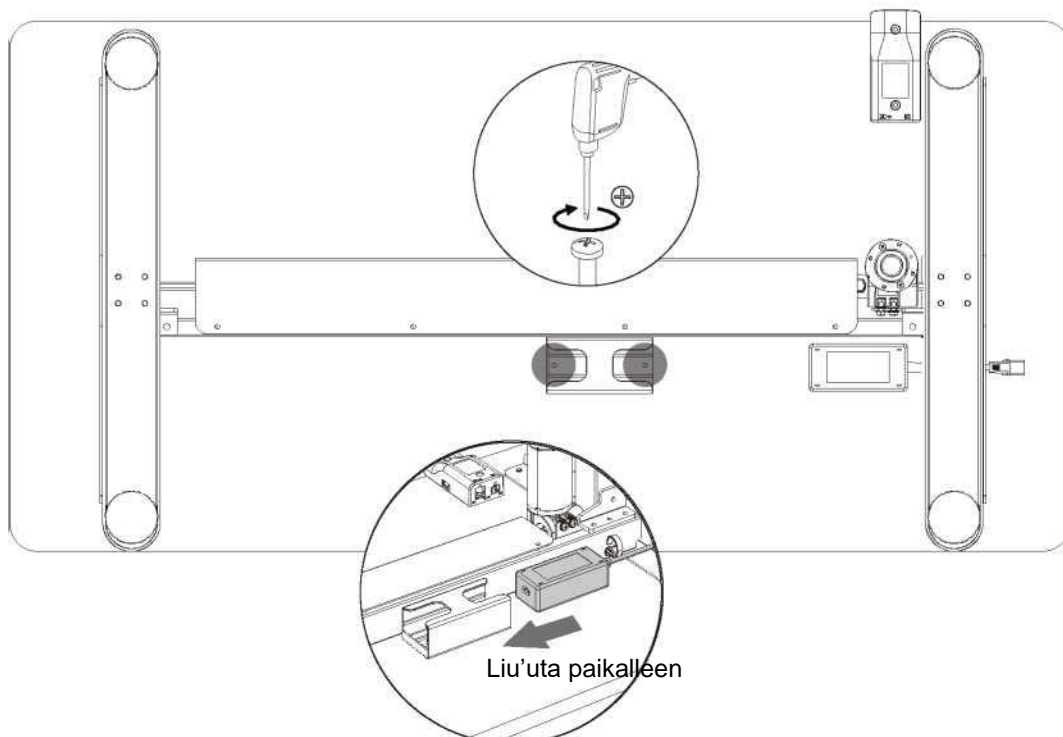



**VAIHE 10**

Sido johto

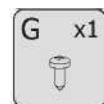

Ei sisälly

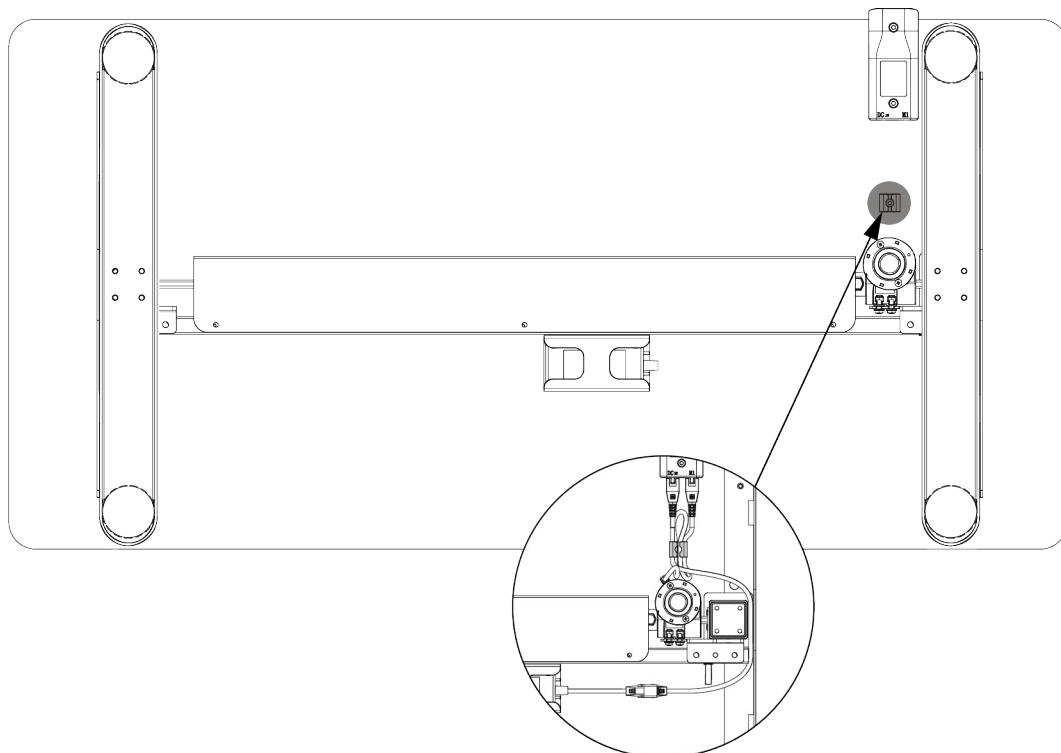

**VAIHE 11**

Asenna koukku

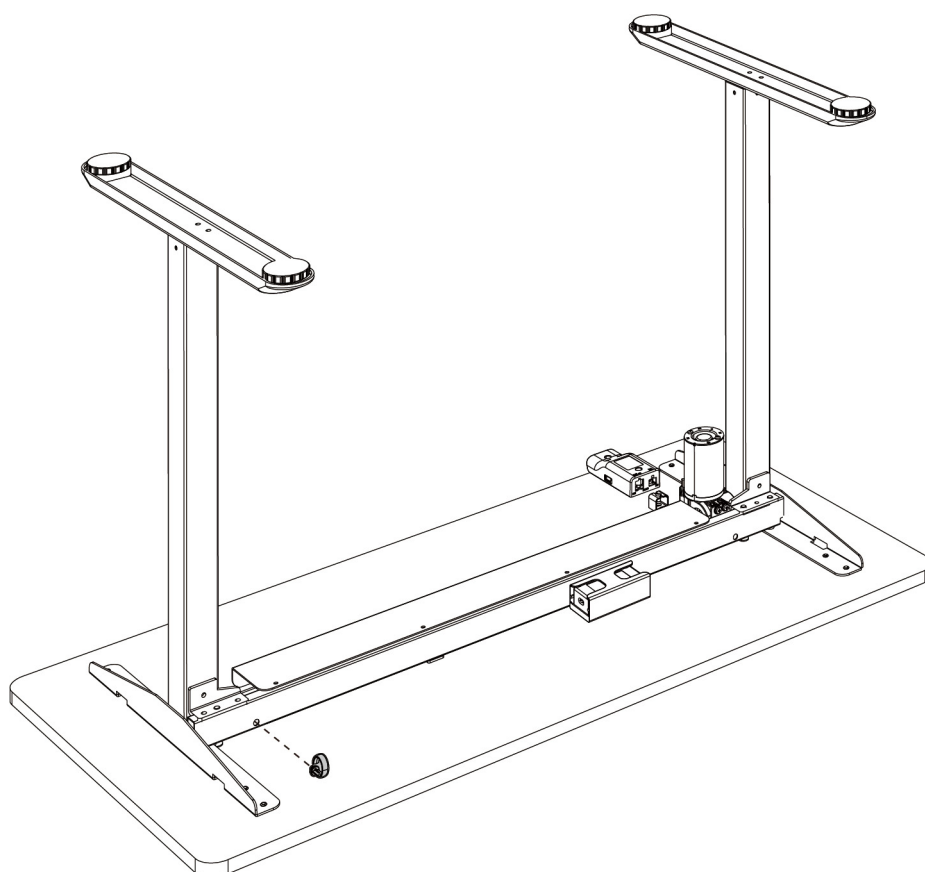

**VAIHE 12**

**Sido johto**

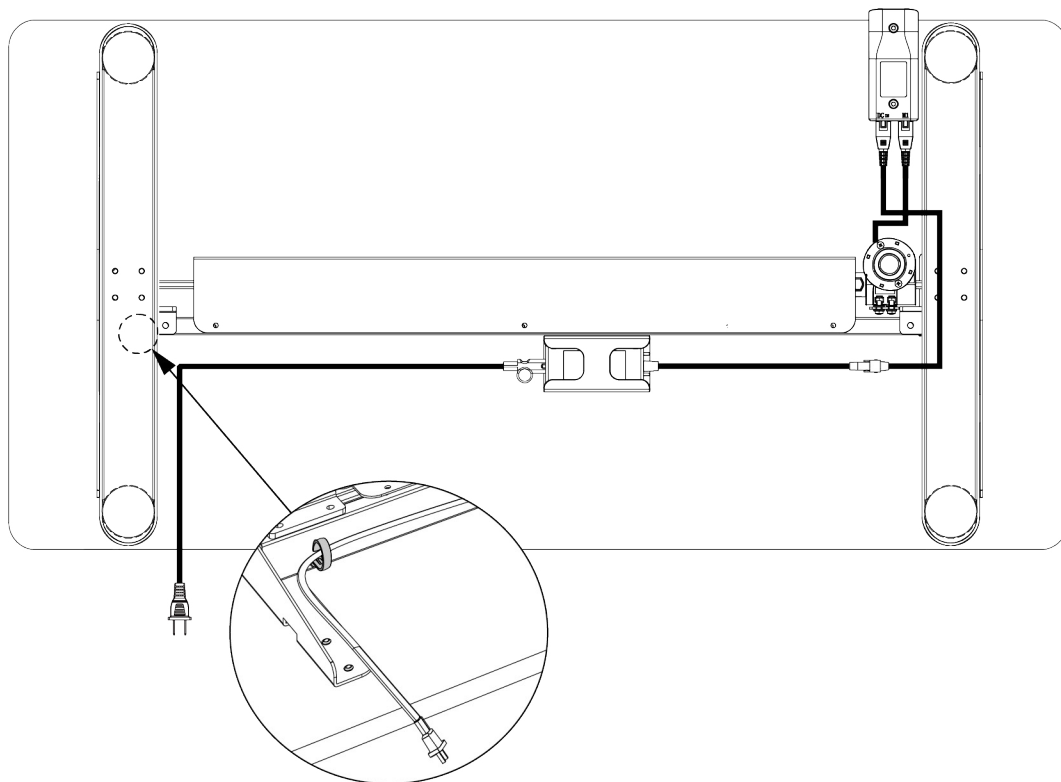

## Säätimen painikkeiden toiminta

Pöydän nostaminen

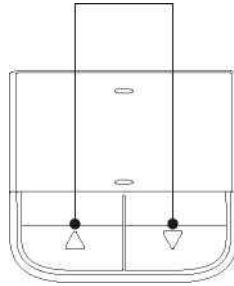

Huomio

Varmista, ettei mikään estä pöytälevyä nousemasta tai laskemasta ja että kaikki johdot ovat tarpeeksi pitkiä.

### • Nollaustoiminto:



- Paina alimmassa asennossa alas-painiketta yli 5 sekunnin ajan siirtyäksesi nollaustilaan. Kun nostojärjestelmä saavuttaa ala-asennon ja pysähtyy, nollaus on suoritettu.
- Jos nostojärjestelmä ei toimi, vapauta painike ja paina pitkään alas-painiketta, kunnes nostojärjestelmä on ala-asennossa ja pysähtyy, nollaus on suoritettu.

### • Vianmääritys:



- Jos ylös- tai alas-painike lakkaa toimimasta yhtäjaksoisen käytön jälkeen, odota 18 minuuttia ja kokeile uudelleen.
- Jos pöytälevy laskee hieman alas nostamisen aikana, tarkista, onko pöytä ylikuormitettu ja täriseekö pöytä voimakkaasti.

## Yleisimmät ongelmat

Seuraavat vinkit auttavat sinua havaitsemaan ja korjaamaan yleisimmät ongelmat ja virheet. Jos kohtaamasi ongelma ei ole lueteltu alla, ota yhteyttä jälleenmyyjään. Vain valmistaja ja ammattilaiset pystyvät tutkimaan ja korjaamaan kyseiset viat.

Vika	Toimenpide
Pöytä ei liiku	Tarkista kaikkien johtojen liitokset
Pöytä nousee hitaasti	Tarkista ylikuormituksen varalta, maksimikuorma: 50 kg
Pöytä liikkuu itsestään alaspäin	
Pöytä nollautuu itsestään	
Pöytä liikkuu alas, mutta ei ylös, tai ylös, mutta ei alas	Nollaa
Ylä- tai ala-asennon korkeus ei riitä	
Pöytä ei nouse	
Ylikuormitus (Käyttösuhte: enintään 2 minuuttia päällä/18 minuuttia pois päältä)	Kokeile uudelleen 18 minuutin kuluttua, kun virta on kytkettynä.

## Huomio

1. Virtalähde: AC 100–240 V, 50/60 Hz
2. Käyttölämpötila: 0–40 °C
3. Irrota pistotulppa pistorasiasta ennen puhdistamista. Pyyhi pöly pinnalta hieman kostealla liinalla. Älä päästä vettä osien sisälle äläkä irrota liittimiä.
4. Ohjauslaite sisältää elektronisia komponentteja, metalleja, muoviva, johtoja jne., joten hävitä se ympäristölainsäädännön mukaisesti.
5. Tarkista, että asennus on tehty oikein ja kokonaan ennen käyttöä.
6. Tutustu laitteen kaikkiin toimintoihin ja ohjelma-asetuksiin ennen ensimmäistä käyttöä.
7. Lapset eivät saa leikkiä tuotteella. Valmistaja ei ota vastuuta siitä aiheutuvista vahingoista.
8. Vetohihnan tai jarrujärjestelmän rakenteesta johtuva lievä melu ei vaikuta laitteen käyttöön.
9. Älä käytä syövyttäviä tai hankaavia aineita laitteen puhdistamiseen. Varmista, että käytettävä puhdistusaine ei saastuta ympäristöä.
10. Tätä laitetta saa käyttää yli 8-vuotiaat lapset ja sellaiset henkilöt, joiden fyysiset, aistilliset tai henkiset kyvyt ovat heikentyneet tai joilla ei ole kokemusta tai tietoa, jos heitä valvotaan käytön aikana tai heitä on ohjeistettu laitteen turvalliseen käyttöön ja he tiedostavat käyttöön liittyvät vaarat. Lapset eivät saa leikkiä laitteella.
11. Lapset eivät saa puhdistaa ja huoltaa laitetta ilman aikuisen valvontaa.
12. Jos virtajohto on vaurioitunut, valmistajan, sen huoltoedustajan tai vastaavan pätevyyden omaavan henkilön on vaihdettava se vaaran välttämiseksi.
13. Varmista, ettei käyttöympäristössä ole vaaralähteitä. Älä esimerkiksi jätä työkaluja pöydän ympärille. Käsittele pakkausmateriaaleja aina varoen välttääksesi mahdolliset vaarat. Esimerkiksi muovipussi voi aiheuttaa tukehtumisvaaran lapsille.
14. Siirrä pöytä kahden tai useamman henkilön voimin ja varmista, ettei pöydällä ole mitään. Sulje laatikot, ovet jne. Varmista myös, että ruuvit eivät ole löysällä ja irrota pistoke pistorasiasta. Säilytä tarvittaessa tämän tuotteen alkuperäinen pakkaus siltä varalta, että tarvitset sitä myöhempää kuljetusta varten.
15. Kun säilytät pöytää pitkään, irrota pistoke pistorasiasta, poista helposti putoavat esineet ja säilytä se viileässä ja kuivassa paikassa.

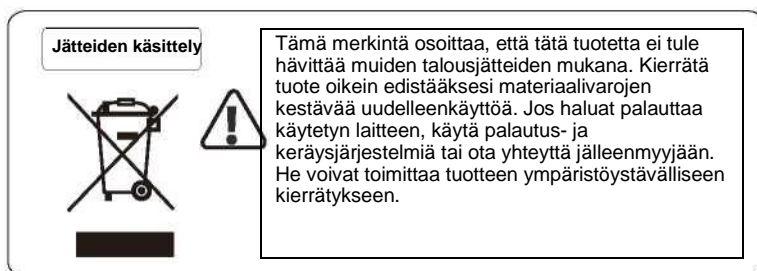

**SUOMITRADING**

Suomi Trading Oy

Areenakatu 7, 37570 Lempäälä

[asiakaspalvelu@suomitradings.fi](mailto:asiakaspalvelu@suomitradings.fi)

## **GXT classic elektriskt bord 1200x600mm**

### **Montering**



< Bilderna nedan är endast för referens, se den faktiska produkten.>

Läs noggrant igenom denna bruksanvisning före användning. Spara anvisningarna

# Bruksanvisning

---

## Uppfyllda standarder

EN1730

EN527

BIFMA5

## Tekniska specifikationer

---

Ben	2
Maximal bärighet	50 kg
Maximal hastighet	15 mm/s
Lägsta höjd	730 mm
Högsta höjd	1 180 mm
Bordskivans storlek	1 200 x 600 mm

## Produktlista

---

### Dellista

Observera: Bilderna nedan är endast vägledande och kan skilja sig något från de produkter och den utrustning som levereras. Kontakta kundtjänst om du saknar en del eller har problem med installationen.

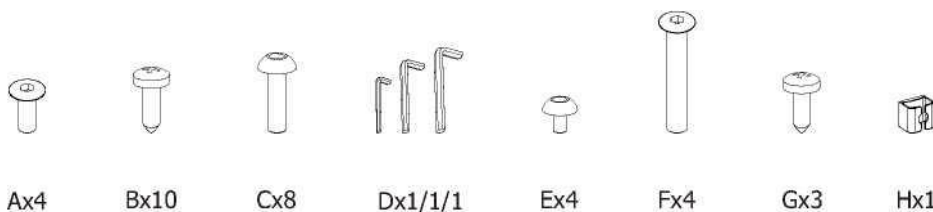

### Förberedelser före montering

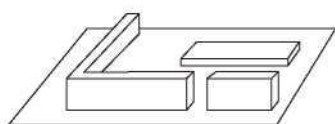



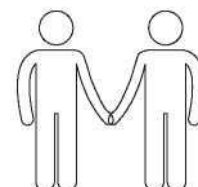











Montera bordet på mattan för att undvika repor. En skruvdragare behövs.



Sätt ihop bordet med två eller flera personer.

## Dellista

Nr	Del	Nr	Del
①	Bordsskiva x1 	⑧	Skydd x1 
②	Stödplatta x2 	⑨	Styrenhet x1 
③	Balk x1 	⑩	Nätadapter x1 
④	Vänster ben x1 	⑪	Nätadapterhållare x1 
⑤	Höger ben x1 	⑫	Stickkontakt x1 
⑥	Fot x2 	⑬	Brytarledning x1 
⑦	Lyftaxel x1 	⑭	Krok x1 

## Monteringsanvisningar

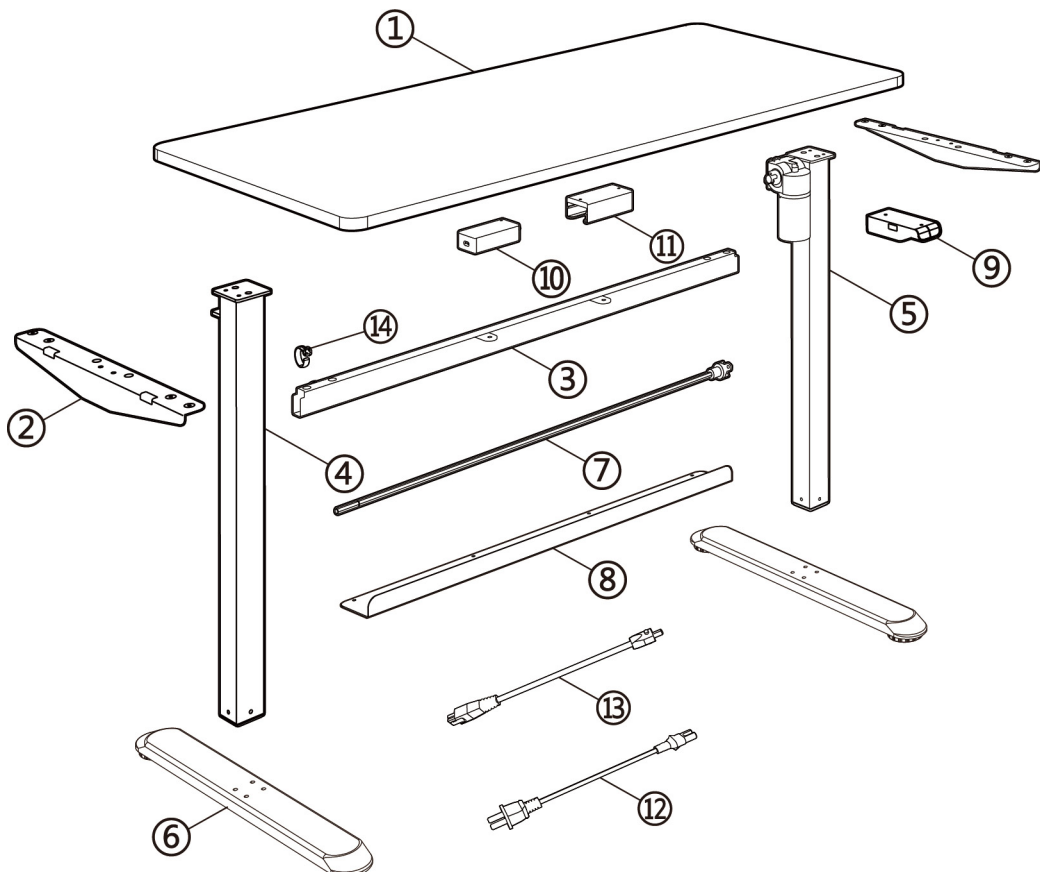



# Installationssteg

STEG 1

Montera fötterna

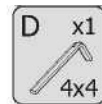
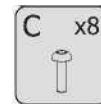
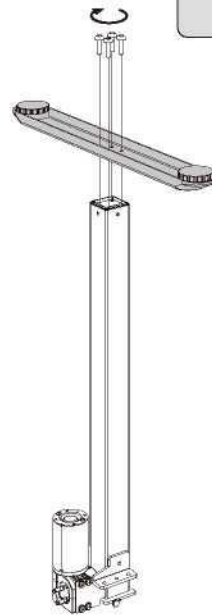
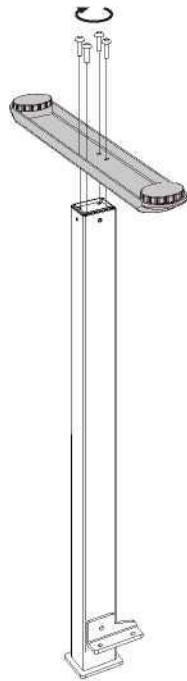

STEG 2

Fäst det högra benet till balken

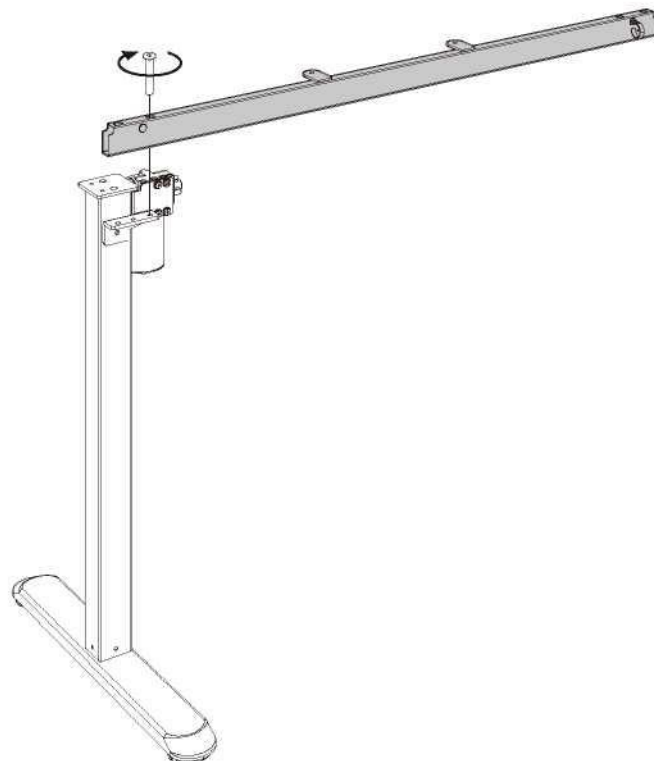
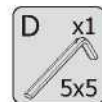
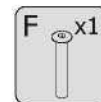

STEG 3

Montera lyftaxeln

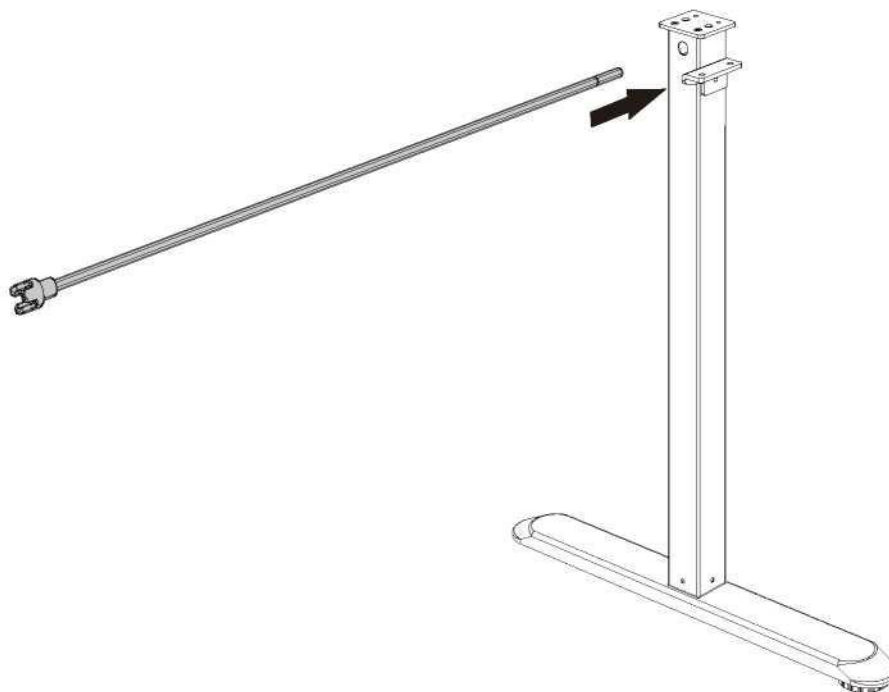

! Vid installationen måste man se till att höjden det vänstra och högra benet är densamma.

E x1  
2.5x2.5

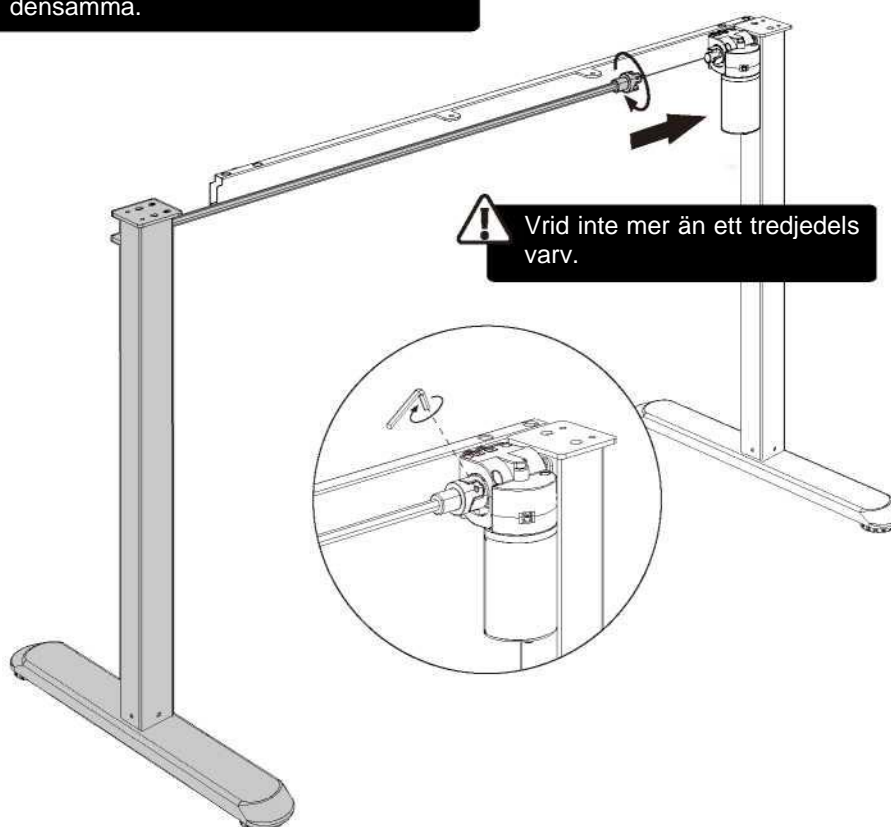

! Vrid inte mer än ett tredjedels varv.

STEG 4

Fäst det vänstra benet till balken

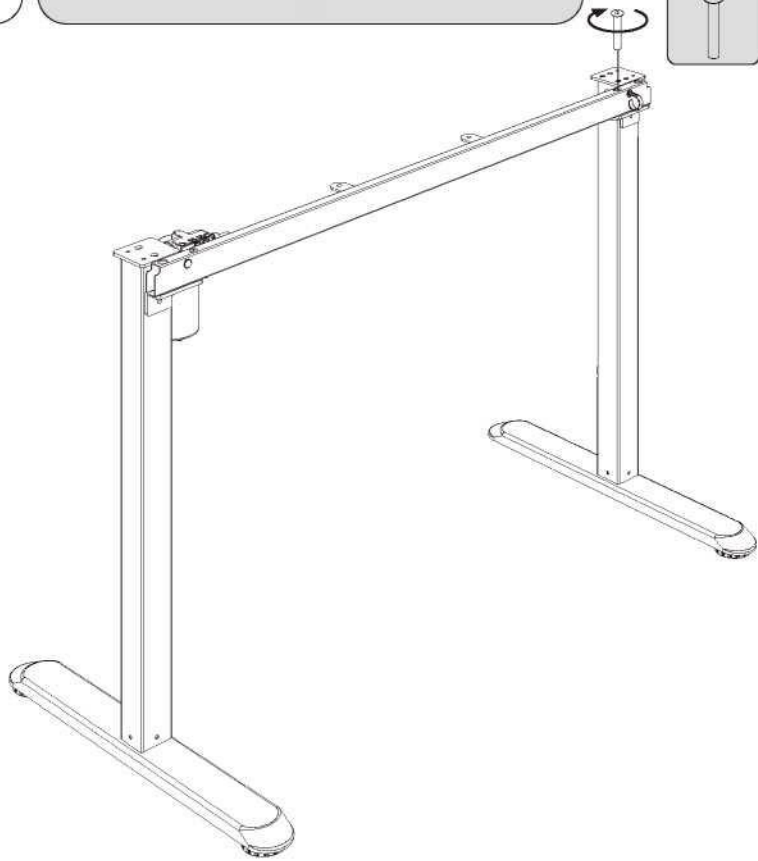
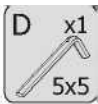
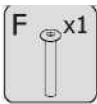

STEG 5

Montera stödsnivorna

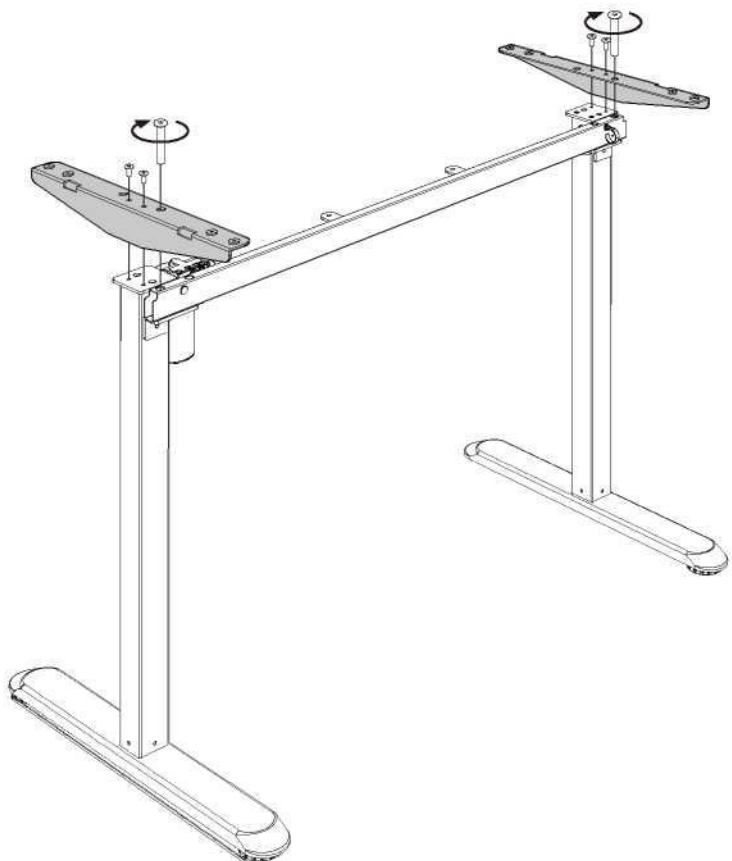
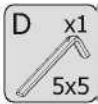

STEG 6

Montera bordsskivan

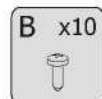

Ingår ej

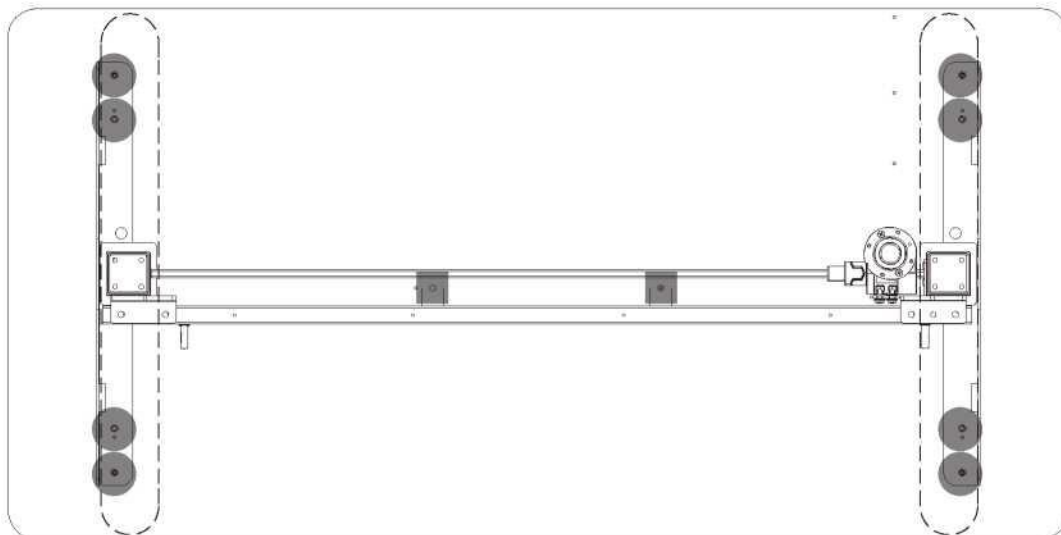
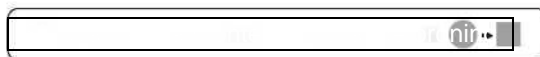

STEG 7

Montera skyddet

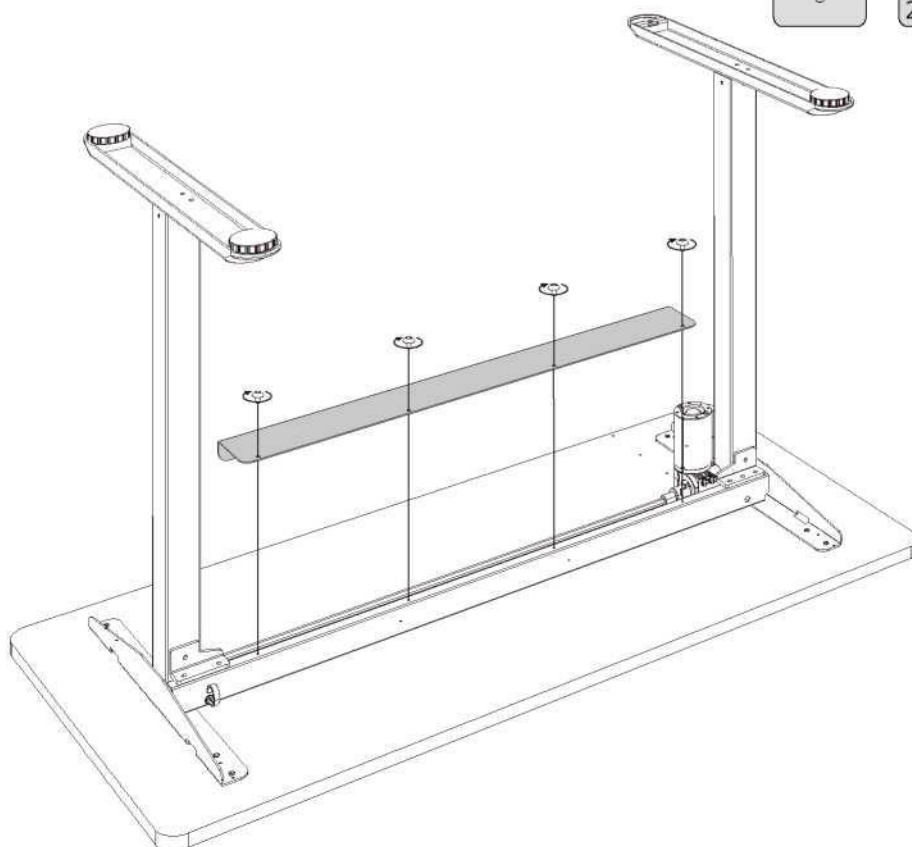
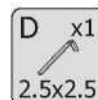
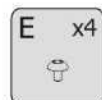

STEG 8

Montera styrenheten



Ingår ej

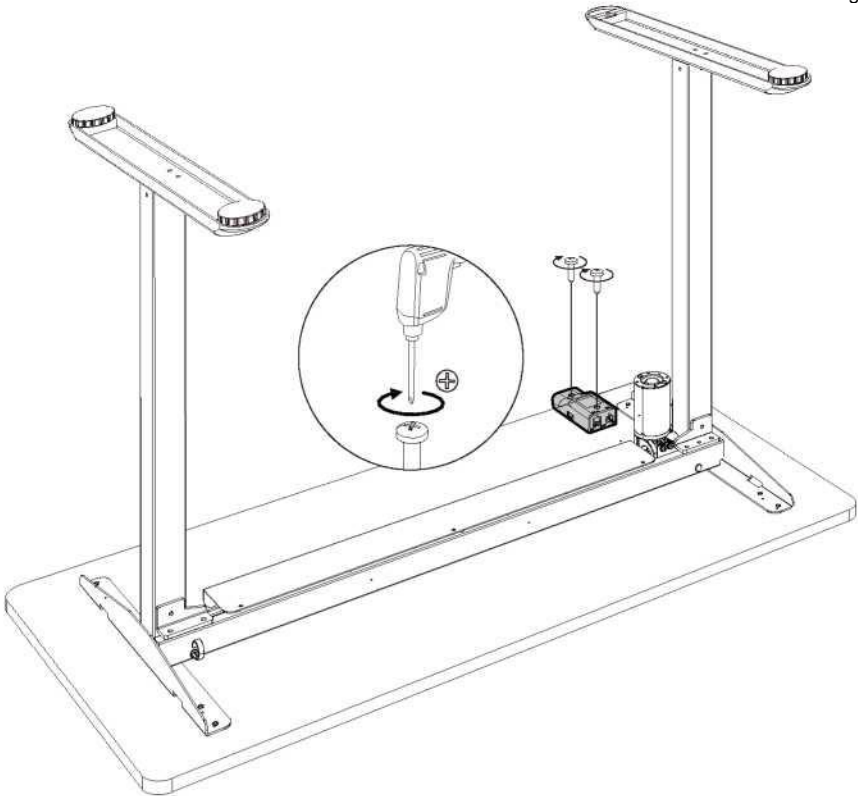

STEG 9

Montera nätadaptern



Ingår ej

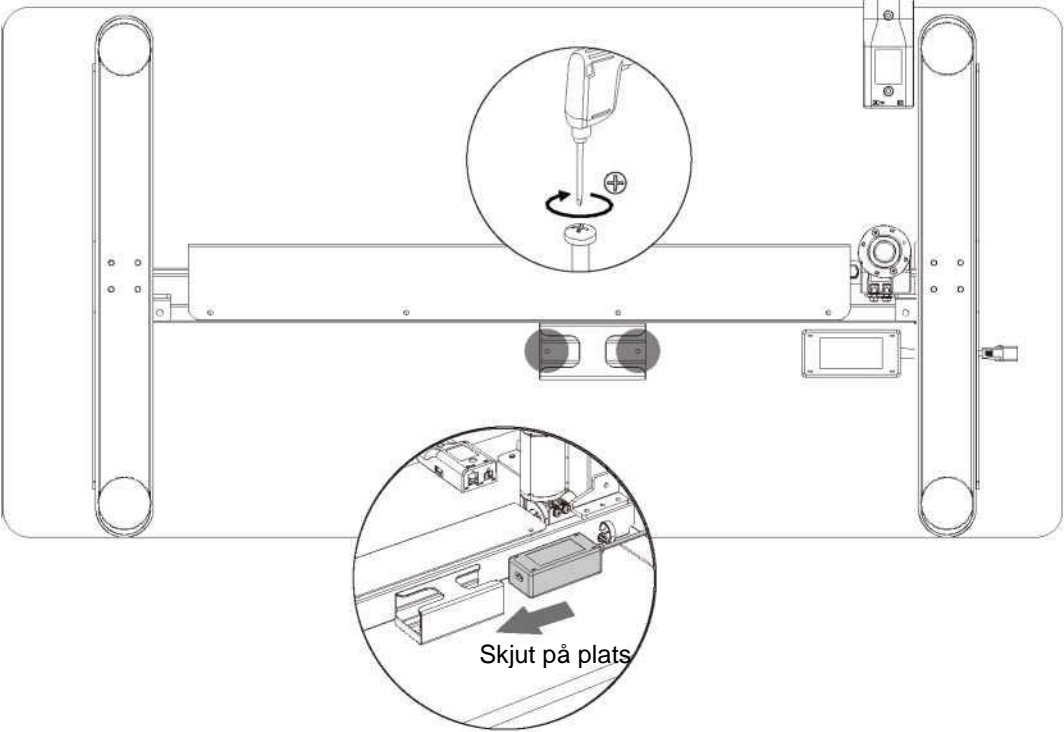

STEG 10

Fäst kablarna

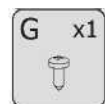

Ingår ej

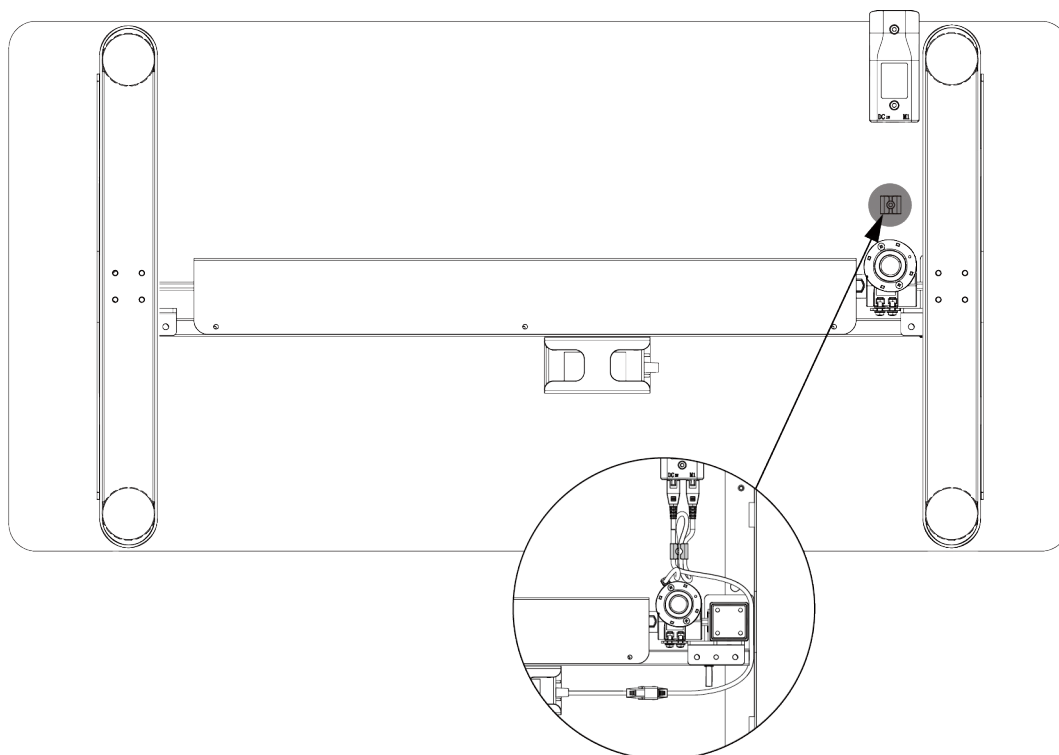

STEG 11

Installera kroken

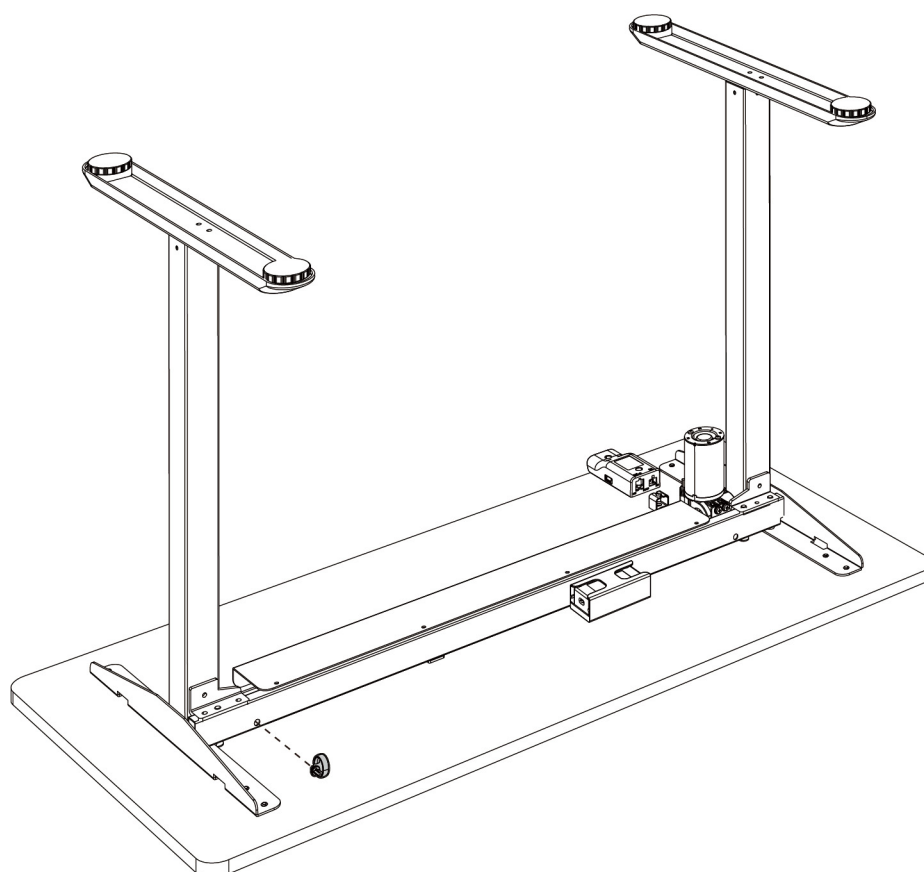

STEG 12

Anslut kablarna

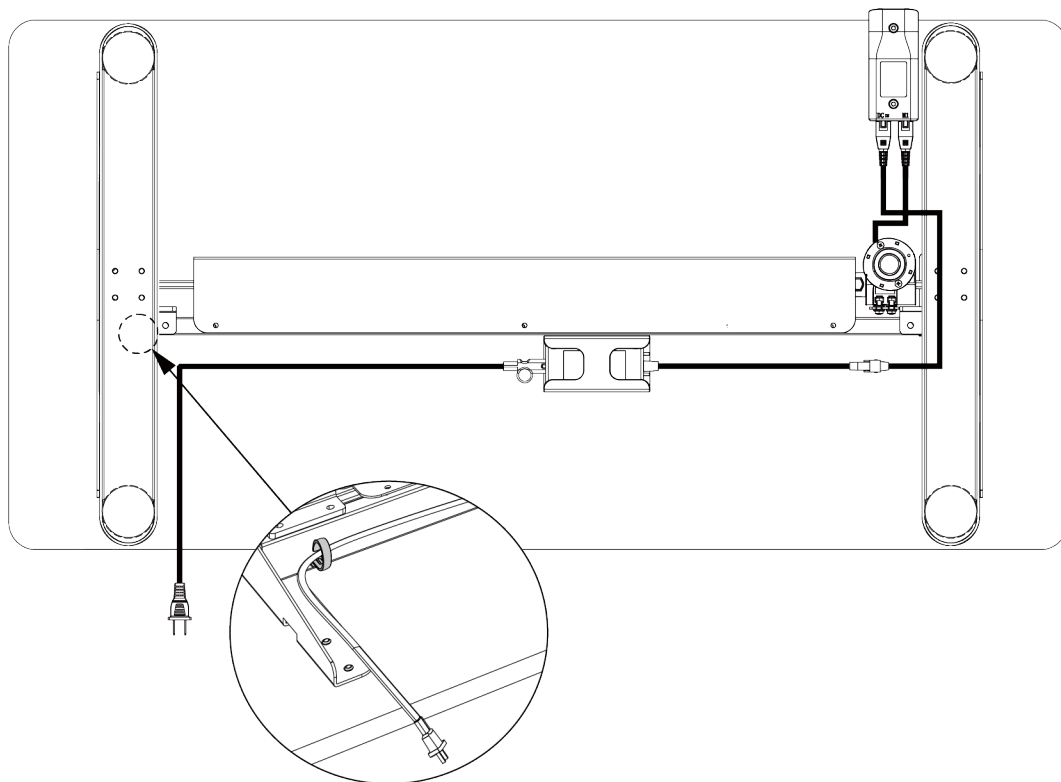

## Användning av knapparna på styrenheten

Lyfta bordet

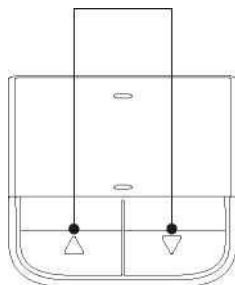

Observera

Se till att det inte finns något som hindrar bordsskivan från att stiga eller sjunka och att alla kablar är tillräckligt långa.

### • Återställningsfunktion:



- I det lägsta läget trycker du på nedåtknappen i mer än 5 sekunder för att gå in i återställningsläget. När lyftsystemet når bottenläget och stannar är återställningen klar.
- Om lyftsystemet inte fungerar släpper du knappen och trycker och håller nedåtknappen intryckt tills lyftsystemet är i bottenläge och stannar, återställningen är klar.

### • Felsökning:



- Om upp- eller nedknappen slutar fungera efter kontinuerlig användning, vänta 18 minuter och försök igen.
- Om bordsskivan sjunker något under lyftningen ska du kontrollera om bordet är överbelastat och om det finns starka vibrationer.



## Vanliga problem

Fel	Åtgärd
Bordet rör sig inte	Kontrollera ledningsanslutningarna
Bordet höjs långsamt	Kontrollera överbelastning, maximal belastning: 50 kg
Bordet sänks av sig själv	
Bordet återställer sig själv	
Bordet rör sig nedåt men inte uppåt, eller uppåt men inte nedåt	Återställ
Höjden på den övre eller nedre positionen är inte tillräcklig	
Bordet stiger inte	
Överbelastning (Arbetscykel: högst 2 minuter på/18 minuter av)	Försök igen efter 18 minuter när strömmen är ansluten.

## Observera

1. Strömkälla: AC 100–240 V, 50/60 Hz
2. Brukstemperatur: 0–40 °C
3. Dra alltid ut nätsladden från vägguttaget före rengöring. Torka av bordet med en lättfuktad trasa. Låt inte vatten tränga in i delarna och dra inte ur kontakterna.
4. Styranordningen innehåller elektroniska komponenter, metaller, plaster, ledningar o.s.v., kassera den i enlighet med miljöföreskrifter.
5. Kontrollera att monteringen är korrekt utförd och komplett före användning.
6. Bekanta dig med enhetens alla funktioner och programinställningar före du använder den för första gången.
7. Låt inte barn leka med produkten. Tillverkaren ansvarar inte för eventuella skador.
8. Lätt ljud orsakat av drivremmen eller bromssystemet påverkar inte produktens funktion.
9. Använd inte frätande eller slipgörande ämnen när du rengör produkten. Se till att det rengöringsmedel som du använder inte förorenar miljön.
10. Denna produkt är inte avsedd för användning av personer under 8 år eller personer med nedsatt fysisk, sensorisk eller mental förmåga, eller brist på erfarenhet eller kunskap, såvida de inte är under uppsikt under användning eller har fått instruktioner om säker användning och känner till farorna vid användning. Låt inte barn leka med denna apparat.
11. Låt inte barn rengöra eller utföra underhåll på denna produkt utan uppsikt av en vuxen.
12. Tillverkaren, en servicerepresentant eller motsvarande behörig person ska byta ut en trasig strömsladd.
13. Se till att det inte finns några faror i driftsmiljön. Lämna inte exempelvis verktyg vid bordet. Hantera alltid förpackningsmaterial försiktigt för att undvika eventuella faror. Till exempel plastpåsar kan orsaka kvävningsrisk för barn.
14. Flytta bordet med två eller flera personer och se till att det inte ligger något på bordet under flyttningen. Stäng lådor, dörrar osv. Kontrollera också att skruvarna inte sitter löst och dra ut kontakten ur uttaget. Behåll vid behov produktens originalförpackning om du behöver den för framtida transporter.
15. När du förvarar bordet under längre tid ska du dra ur kontakten, ta bort alla föremål som lätt kan falla och förvara det på en sval och torr plats.

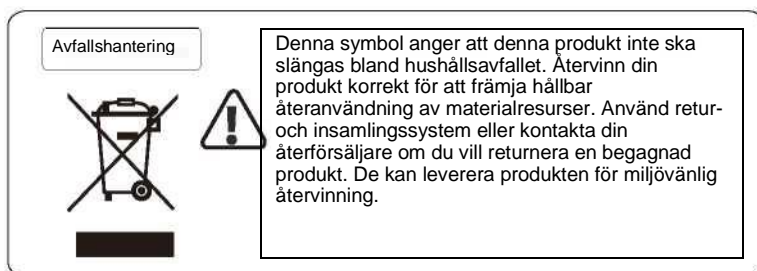

**SUOMITRADING**

Suomi Trading Oy

Areenakatu 7, 37570 Lempäälä

[asiakaspalvelu@suomitrading.fi](mailto:asiakaspalvelu@suomitrading.fi)

# **GXT classic electric table 1200x600mm**

## Installation guide



< The pictures below are for reference only, please refer to the actual product. >

Please read this product manual carefully before use, and keep it properly.

# Instructions for Use

---

## Executive standard

EN1730

EN527

BIFMA5

## Technical Data

---

Column Stage	2
Max. Load Capacity	50 KG
Max. Speed	15mm/s
Lowest Height	730mm
Highest Height	1180mm
Tabletop Size	1200x600mm

## Product List

---

### Accessory List

Attention: The drawings below are for guidance only and they may differ slightly from the product and fittings received. Please contact customer service if there are any missing tools or installation problems.

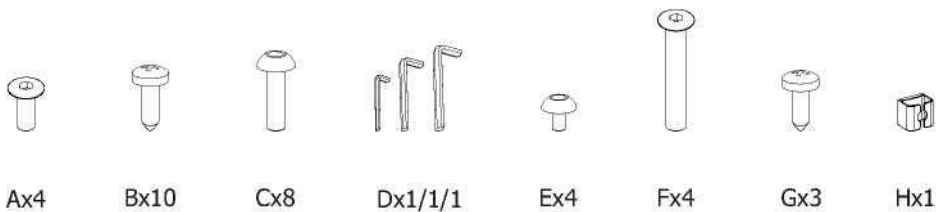

### Preparation before installation

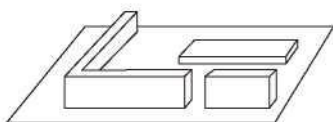



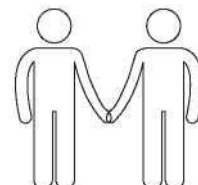











Install on carpet to prevent scratches. Bring your own pistol drill.



Need two or more people to cooperate together.

## Part List

No.	Part	No.	Part
①	Tabletop x1 	⑧	Baffle x1 
②	Supporting plate x2 	⑨	Handset x1 
③	Beam x1 	⑩	Adaptor x1 
④	Left lifting column x1 	⑪	Adaptor holder x1 
⑤	Right lifting column x1 	⑫	Power plug x1 
⑥	Foot x2 	⑬	Switch cord x1 
⑦	Transmission rod x1 	⑭	Hook x1 

## Installation Instruction

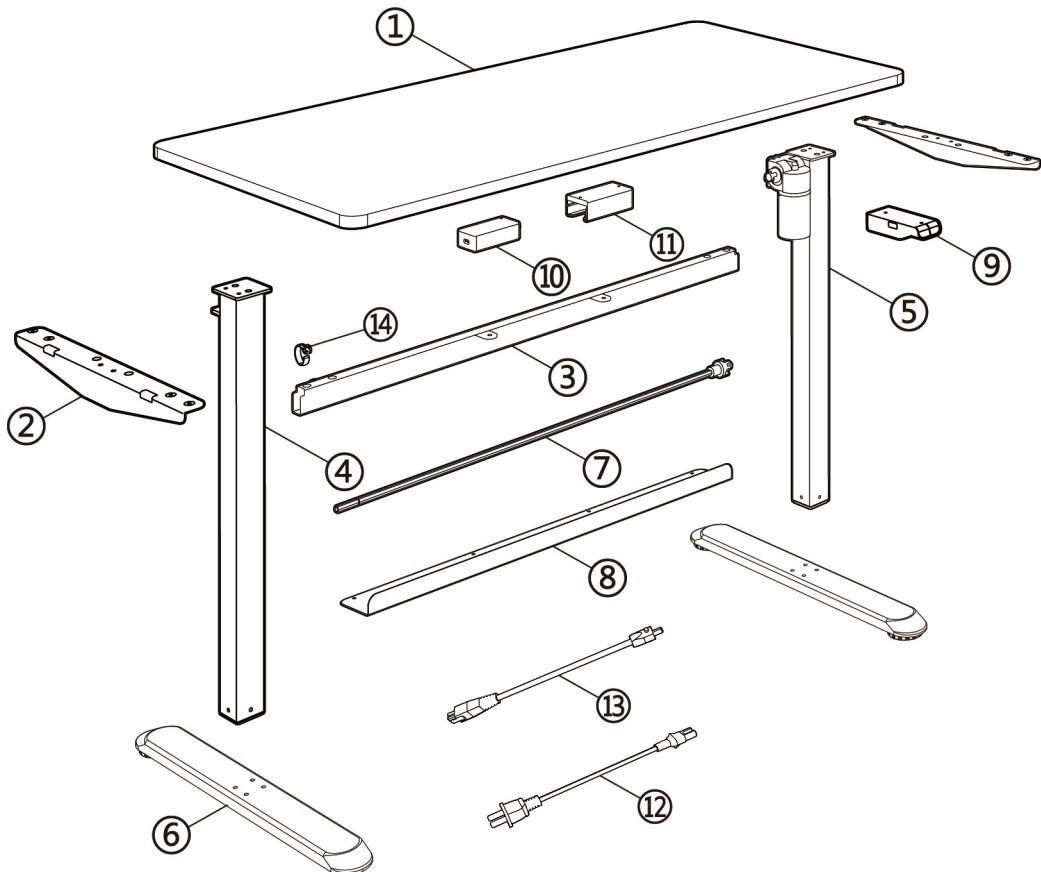

# Installation Steps

STEP1

Install the feet

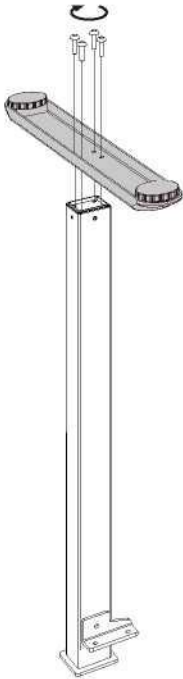
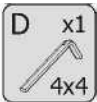
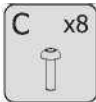

STEP2

Connect the right lifting column to the beam

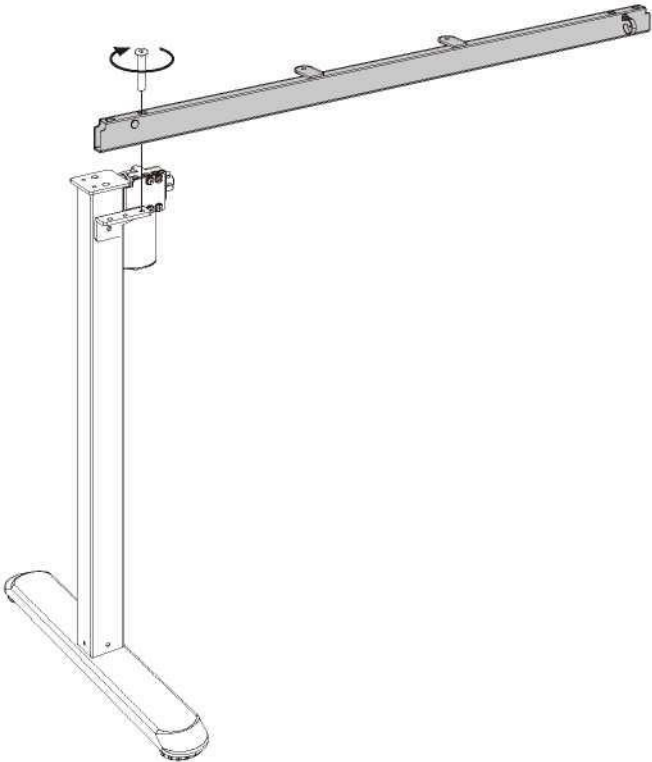
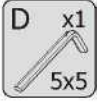

STEP3

Install the transmission rod

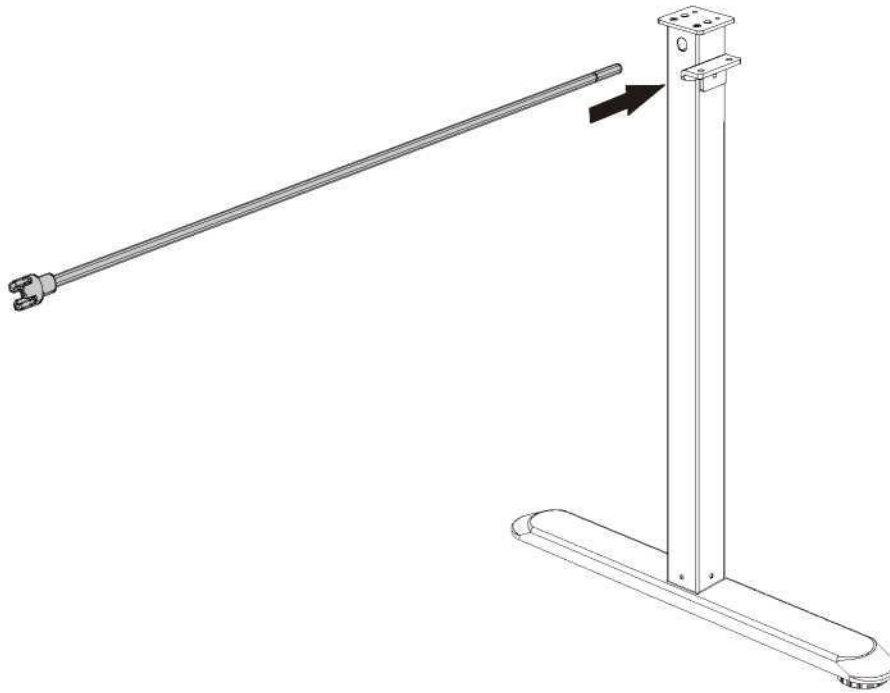

⚠ When installing, please pay attention to keep the height of the left and right columns consistent.



⚠ The rotation degree should not exceed 1/3 turn.

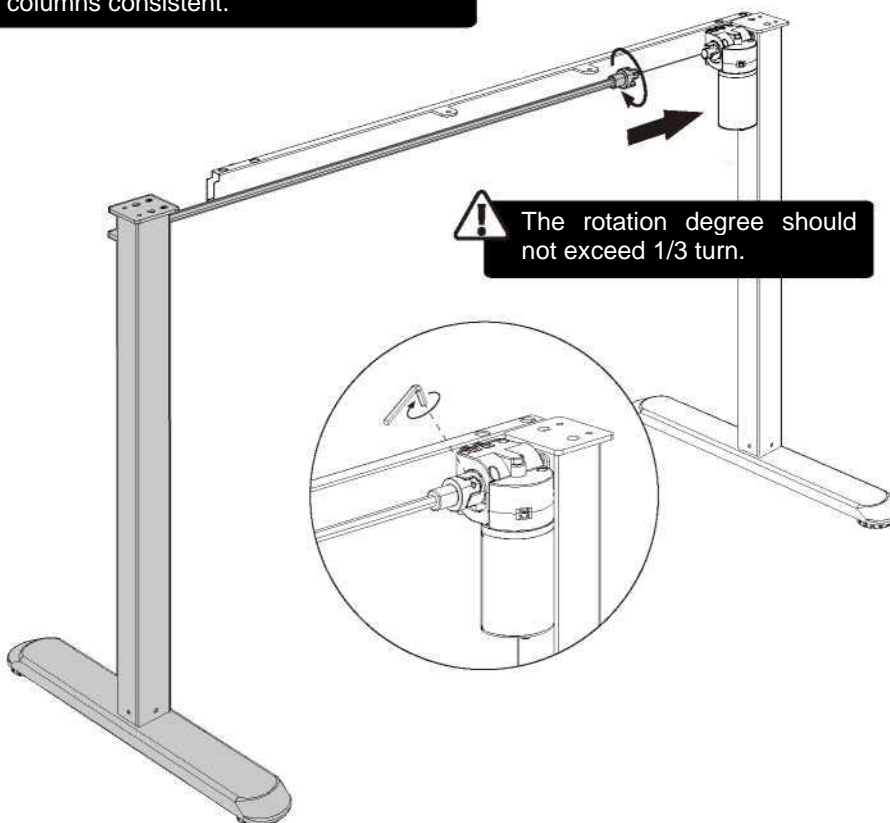

STEP4

Connect the left lifting column to the beam

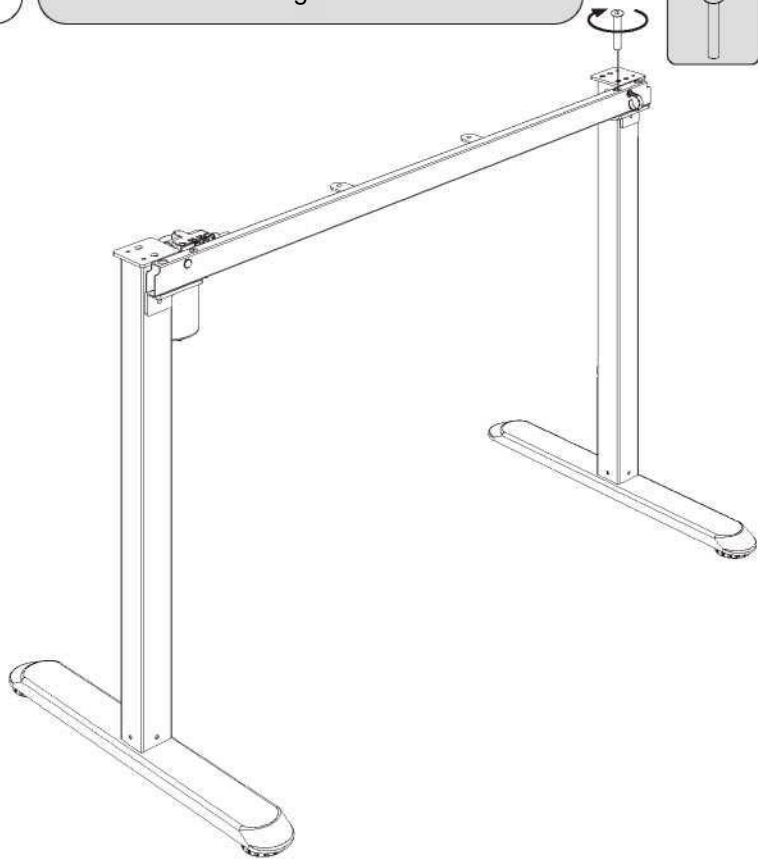
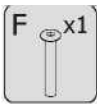

STEP5

Install the supporting plates

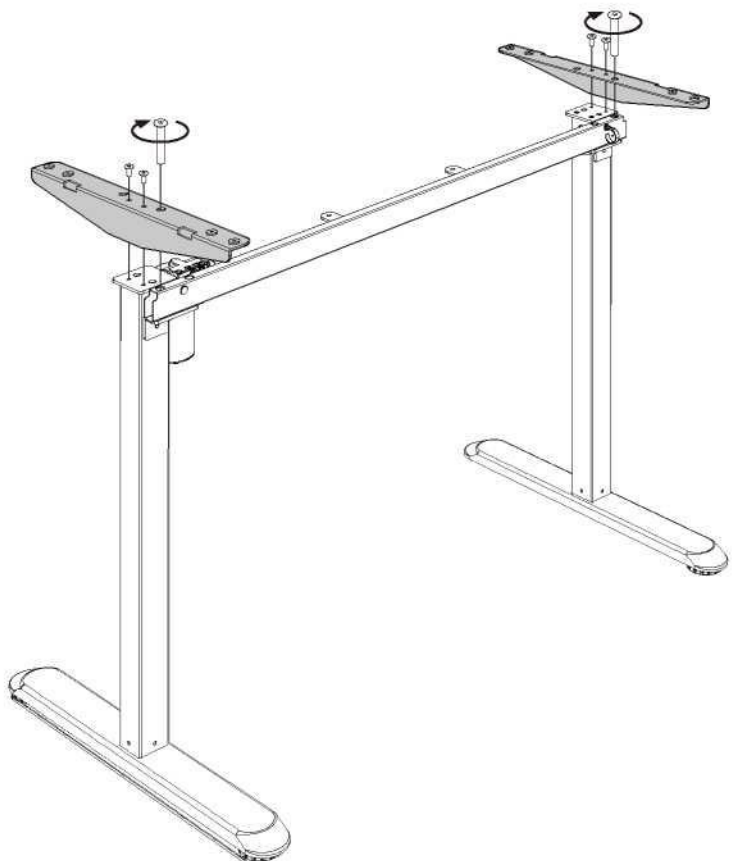
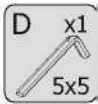



STEP6

Install the tabletop

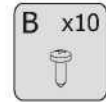

Self-prepared

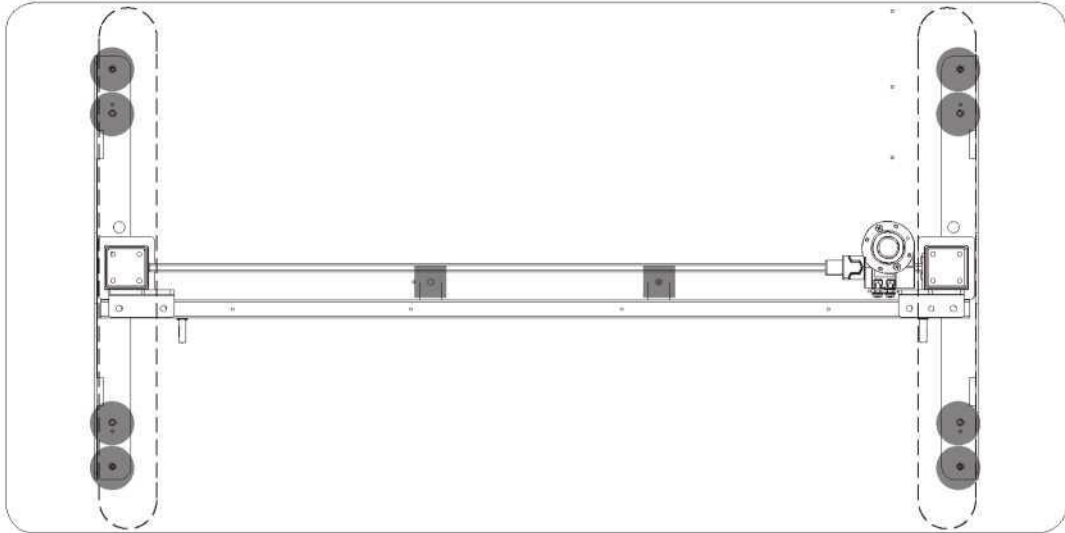

STEP7

Install the baffle

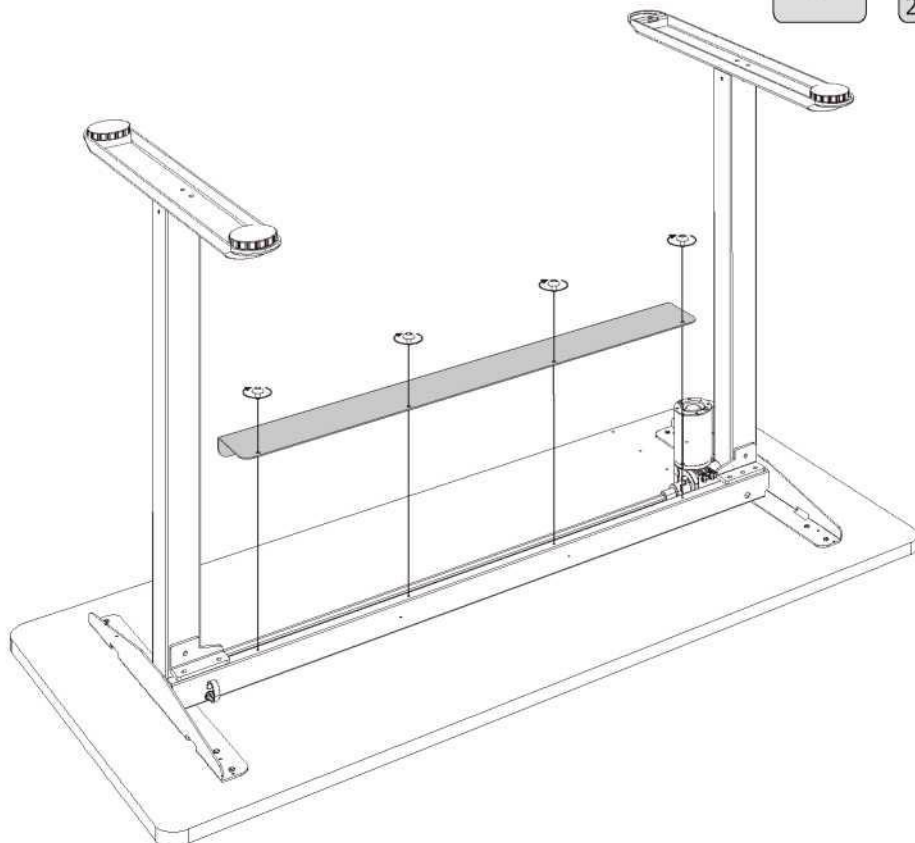
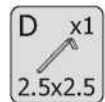

STEP8

Install the handset



Self-prepared

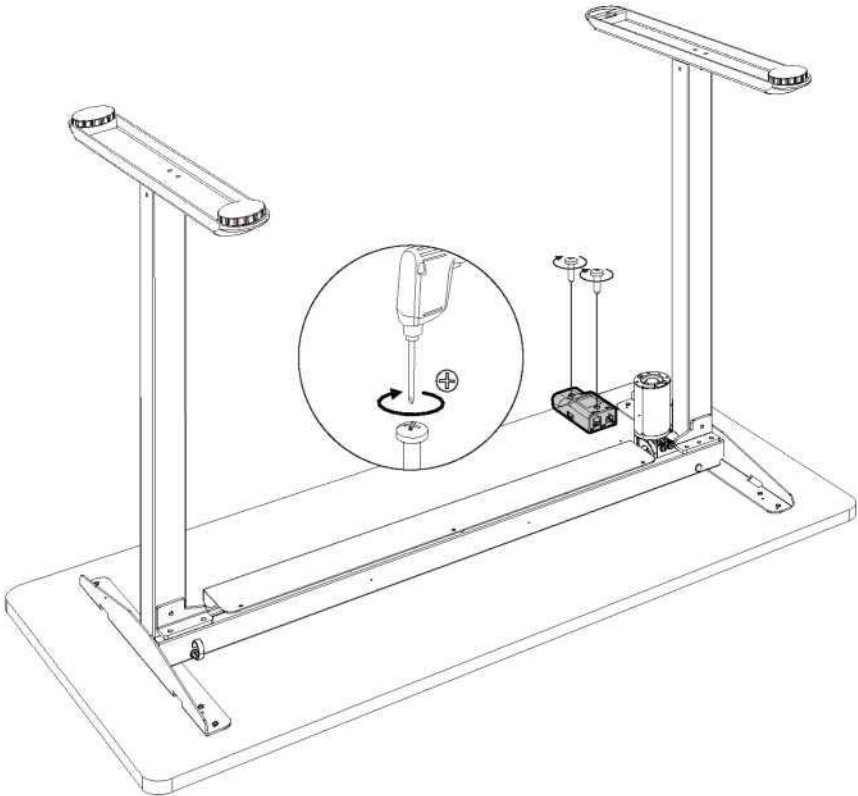

STEP9

Install the adaptor



Self-prepared

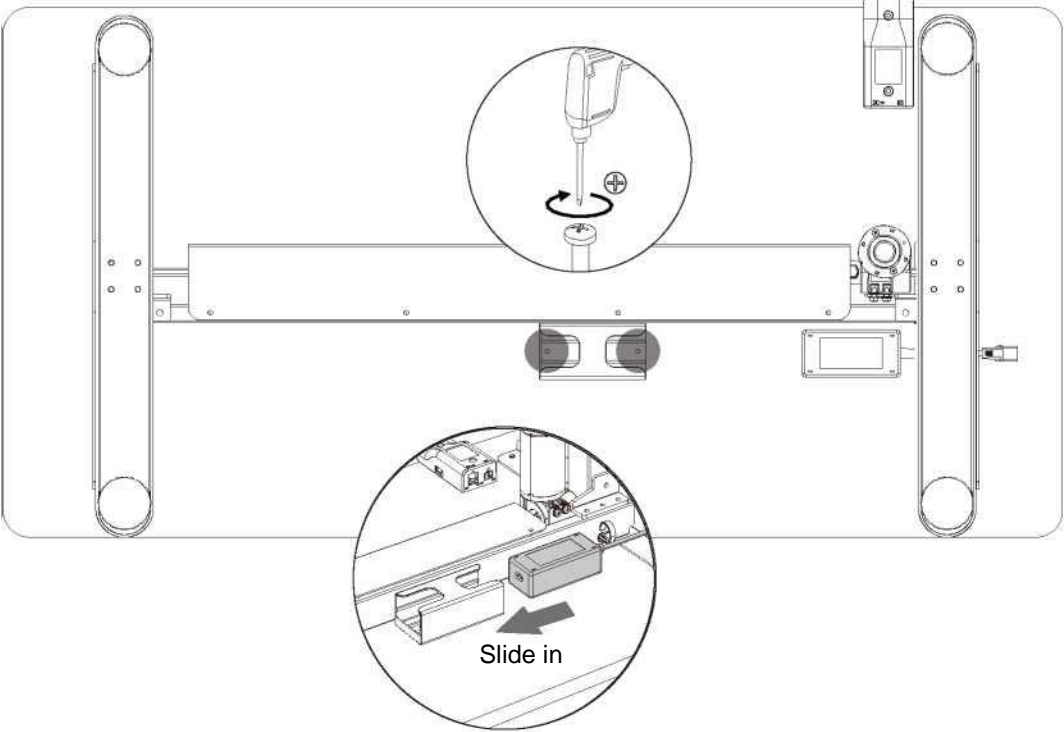

STEP10

Install the cable tie

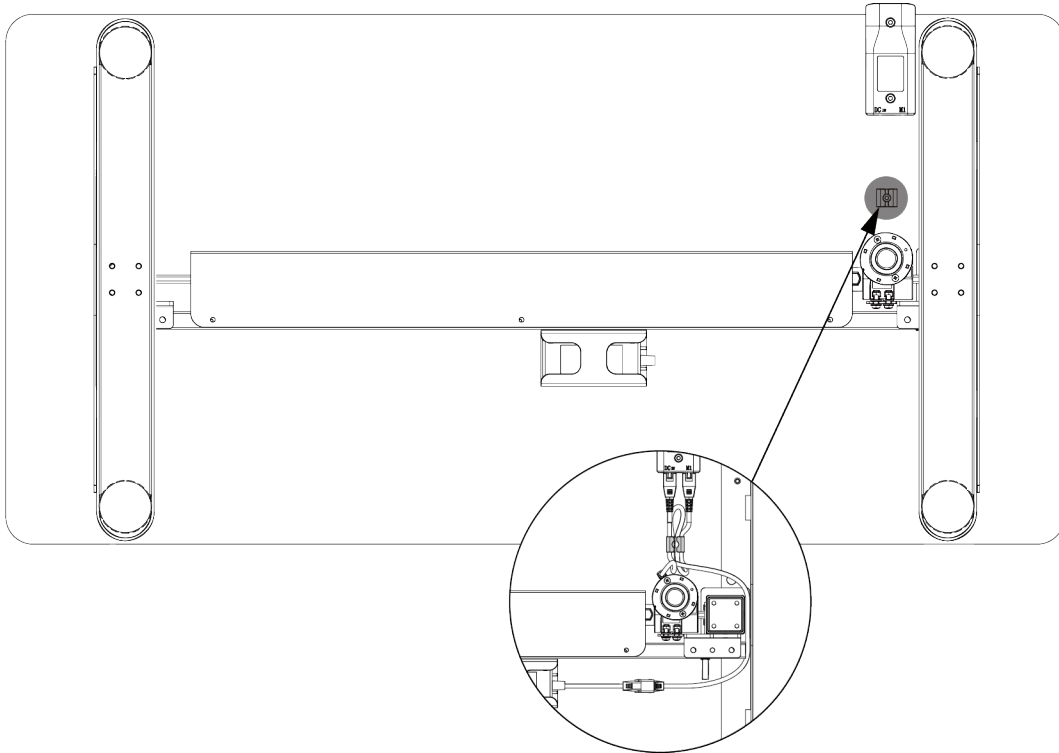

STEP11

Install the hook

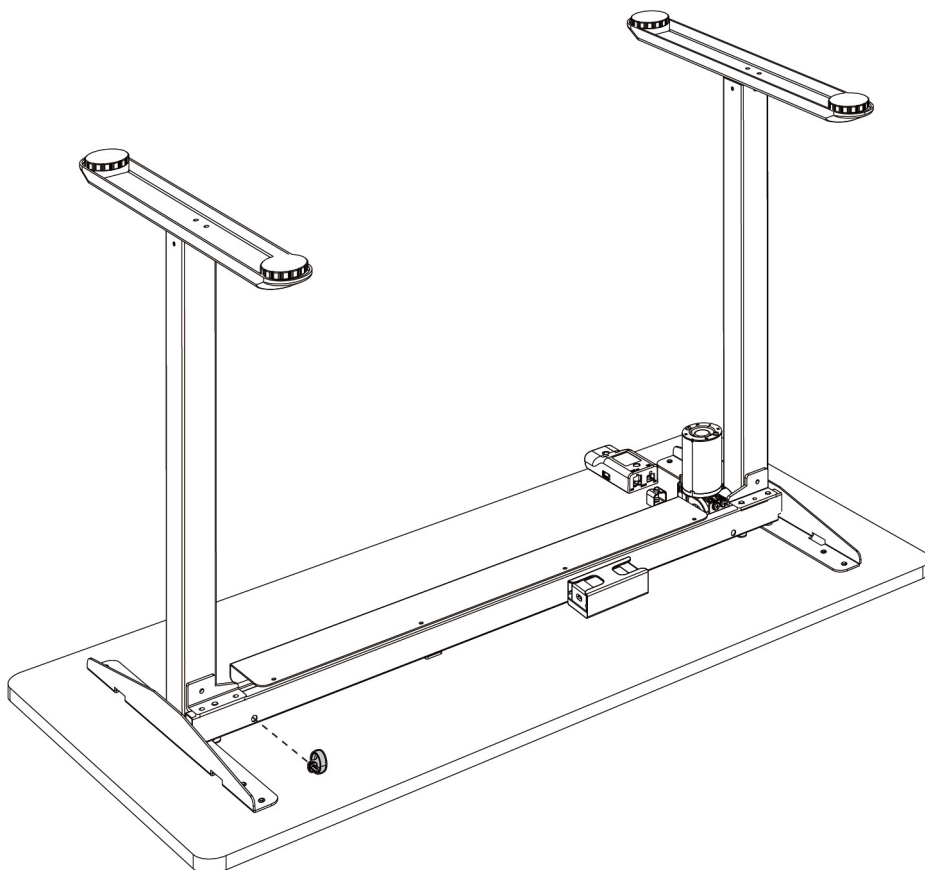

STEP12

Connect the wires

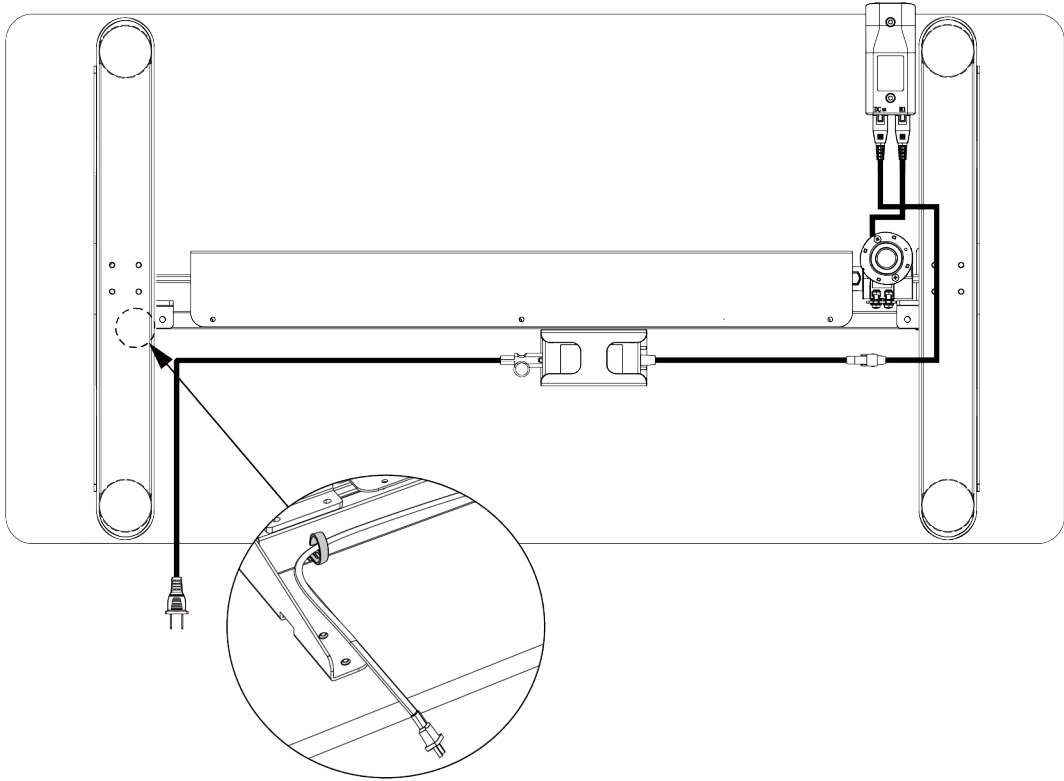

## Handset control method and setting

Desk lift

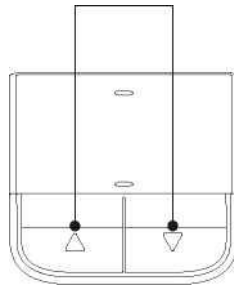

Attention

### • Reset Function:



- a. At the lowest position, long press the down button for more than 5 seconds to enter the reset state, until the lifting system bottoms out and the rebound stops, the reset is successful.
- b. When the lifting system fails, release the button and long press the down button until the lifting system bottoms out and rebounds and stops, and the reset is successful.

### • Troubleshooting:



- a. If there is no response to pressing the up or down button after a period of continuous work, please rest for more than 18 minutes before using it.
- b. During the lifting process, if there is a retreat phenomenon, please check whether the desk load is too heavy and whether the desk shakes greatly.

## Common fault treatment

Fault phenomenon	Method
The desktop could not function	Check if all the cables are well connected;
Rising in a low speed	Check if overloaded, max loading: 50kg;
The desk moving downwards without any operation	
Automatically Self-Reset	
Go down but not go up or go up but not go down	Reset;
The upper and downward height is not enough	
The desk could not lifted	
Overwork (Duty cycle: Max 2min on/18min OFF)	Restart after suspend for 18mins while connecting with power.

## Attention

1. Power supply: AC100V-240V, 50/60Hz
2. Service Environment: 0-40°C
3. Unplug the power plug before cleaning, wipe the dust on surface with slight wet dishcloth when cleaning, be careful not to let the drops into the internal parts, not loose the connector.
4. The electric box contains electronic components, metals, plastics, wires etc., so dispose of it in accordance with each country's environmental legislation, not the general household waste.
5. Check carefully to ensure correct and complete assembly before using.
6. Be familiar with all functions and program settings of the product before first use.
7. Children are forbidden to play on the product because of unforeseen action when playing, so any dangerous consequences caused by this improper action will not be on manufacturers.
8. Slight noise caused by the V-ribbed belt or brake system due to structure will not have any effect on the use of the equipment.
9. Corrosive or abrasive materials are forbidden to clean the equipment. Must ensure that the cleaner used will not pollute the environment.
10. This appliance can be used by children aged from 8 years and above and persons with reduced physical, sensory or mental capabilities or lack of experience and knowledge if they have been given supervision or instruction concerning use of the appliance in a safe way and understand the hazards involved. Children shall not play with the appliance.
11. Cleaning and user maintenance shall not be made by children without supervision.
12. If the supply cord is damaged, it must be replaced by the manufacturer, its service agent or a similarly qualified person in order to avoid a hazard.
13. Please make sure there is no hazard sources in your operating environment, e.g., do not litter the tools around. Always be careful to treat the packaging materials in order to avoid any possible danger, e.g. plastic bag may lead to choking hazard to children.
14. When more than two people are moving the product, please make sure that there is nothing on the table. And close the drawers, doors, etc., also confirm that the screws are not loose, and unplug the power plug. If necessary, please keep the original packaging of this product in case you need to use it for future transportation.
15. When storing for a long time, please unplug the plug, clean up the items that are easy to fall, and store it in a cool and dry place.

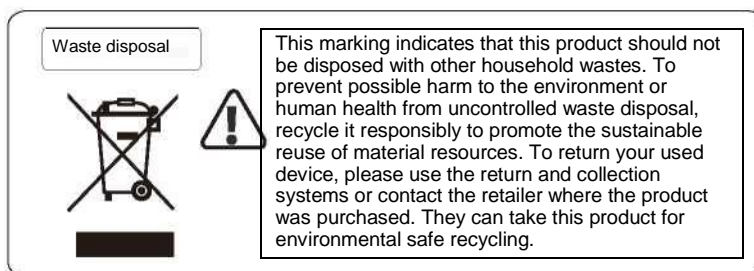

**SUOMITRADING**  
Suomi Trading Oy  
Areenakatu 7, 37570 Lempäälä  
[asiakaspalvelu@suomitradning.fi](mailto:asiakaspalvelu@suomitradning.fi)